

| REV. | DESCRIPTION | DRAWN | CHECKED | APPROVED |
|------|-------------|---------------|---------|----------|
| A | NEW RELEASE | JLZ 04/06/16' | ~ | |
| | | | | |
| | | | | |

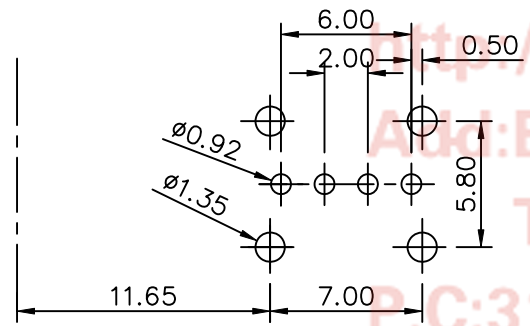
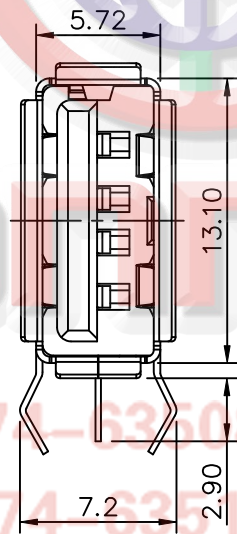
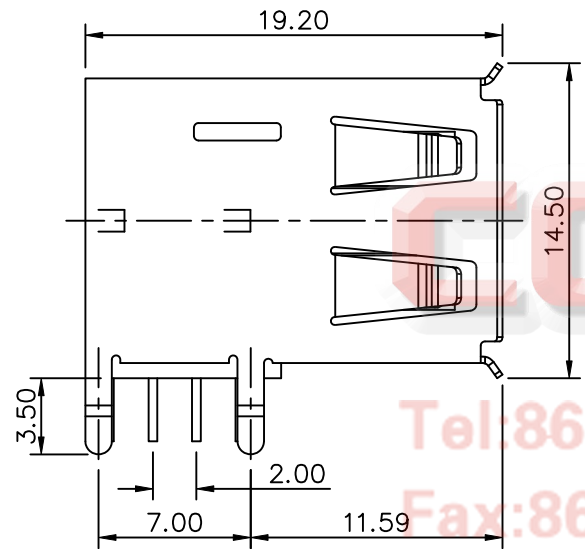
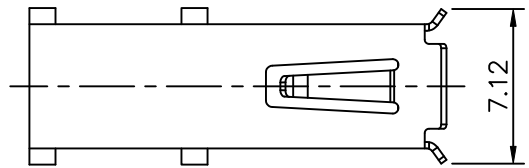

NOTES:

- SPECIFICATIONS:
 - 1.0 CONTACT RESISTANCE: 30mΩ max.
 - 1.1 INSULATOR RESISTANCE: 1000MΩ min. AT DC 500V.
 - 1.2 CURRENT RATING: 1.5A.
 - 1.3 VOLTAGE RATING: 30V AC/DC.
 - 1.4 DIELECTRIC STRENGTH: AC 500V FOR 1 Minute.
 - 1.5 TEMPERATURE RANGE: -40°C ~ +105°C .

- MATERIALS:
 - 2.0 HOUSING: PBT+30% GLASS FIBER(UL 94-0).
 - 2.1 CONTACT: COPPER ALLOY
 - 2.2 SHELL: STEEL

3. PRODUCT NUMBER CODE:

DS1095-01-X X X X - X

- SHELL MATERIAL
F: Steel
- CONTACT PLATING
0: Selective gold flash
03: Selective gold 3u"
30: Selective gold 30u"
- MOUNTING TYPE
R: R/A
- SHELL PLATING:
N: Nickel
6: Tin
- COLOR OF HOUSING:
W: WHITE
B: Black

Tel: 86-574-63510817
Fax: 86-574-63510817

E-mail: sale@connfly.com

http://www.connfly.com

Address: East Industry Zone KuangYan

Town: Cixi Ningbo China
P.C: 315333

| GENERAL TOLERANCE | | ANGLE TOLERANCE | |
|-------------------|-------|-----------------|-----|
| X. | ±0.60 | X. | ±5° |
| .X | ±0.38 | .X | ±3° |
| .XX | ±0.25 | .XX | ±2° |

| PROJECTION | TITLE |
|------------|------------------|
| UNITS | mm |
| SHEET SIZE | A4 |
| SERIES | DS1095-01 SERIES |

RECOMMEND PCB LAYOUT
(TOLERANCE=±0.05)

| DRAWING TYPE | CUSTOMER |
|--------------|---------------------|
| SCALE | 1:1 SHEET 1 OF 1 |
| DRAWING NO. | C-DS1095-01-XXRXX-A |



晨翔电子有限公司
CONNFLY CONNFLY ELECTRONIC CO. LTD