

REV.	DESCRIPTION	DRAWN	CHECKED	APPROVED
A	NEW RELEASE	YCH 08/09/08'		

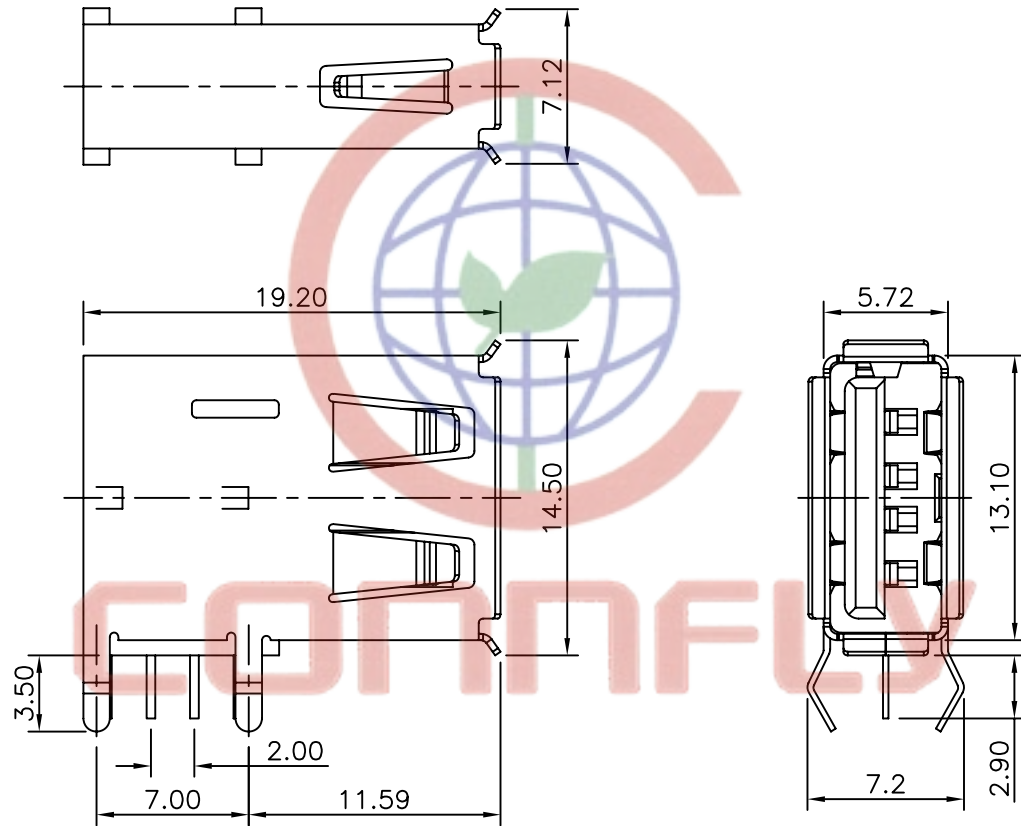

NOTES:

1. SPECIFICATIONS:

- 1.0 CONTACT RESISTANCE: 30mΩ max.
- 1.1 INSULATOR RESISTANCE: 1000MΩ min. AT DC 500V.
- 1.2 CURRENT RATING: 1.5A.
- 1.3 VOLTAGE RATING: 30V AC/DC.
- 1.4 DIELECTRIC STRENGTH: AC 500V FOR 1 Minute.
- 1.5 TEMPERATURE RANGE: -45°C ~ +110°C .

2. MATERIALS:

- 2.0 HOUSING: PBT+30% GLASS FIBER(UL 94-0).
- 2.1 CONTACT: COPPER ALLOY
- 2.2 SHELL: COPPER ALLOY.

3. PRODUCT NUMBER CODE:

DS1095-01-X X X X

CONTACT PLATING
 0: Selective gold flash
 03: Selective gold 3u"
 30: Selective gold 30u"

MOUNTING TYPE
 R: R/A

SHELL PLATING:
 N: Nickel
 6: Tin

COLOR OF HOUSING:
 W: WHITE
 B: Black

SERIES No.
 DS1095-01

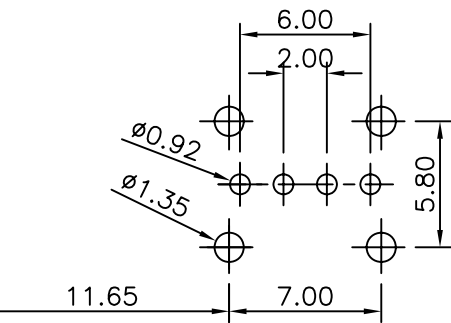

Tel: 86-574-63508787

Fax: 86-574-63510817

E-mail: sales@zhennan.com.cn

Http://www.zhennan.com.cn

West China Ningbo China

P.C:315321

GENERAL TOLERANCE	ANGLE TOLERANCE	PROJECTION		TITLE	USB A TYPE UP RIGHT ANGLE TYPE
X. ±0.60	X. ±5°	UNITS	mm	SHEET SIZE	A4
.X ±0.38	.X ±3°	SHEET SIZE	A4	SERIES	DS1095-01 SERIES
.XX ±0.25	.XX ±2°	DRAWING TYPE CUSTOMER			
DRAWING NO. C-DS1095-01-XXRX		SCALE 1:1 SHEET 1 OF 1			

晨翔电子有限公司
CONNFLY CONNFLY ELECTRONIC CO. LTD