

REV.	DESCRIPTION	DRAWN	CHECKED	APPROVED
A	NEW RELEASE	JLZ 05/14/16'		

NOTES:

1. SPECIFICATION:

- 1.1 CONTACT RESISTANCE: 30mΩ MAX.
- 1.2 DIELECTRIC WITHSTANDING VOLTAGE: 250V AC(rms) FOR 1 MINUTE.
- 1.3 INSULATION RESISTANCE: 500MΩ Min.
- 1.4 OPERATING TEMPERATURE: -40°C~+105°C.

2. PRODUCT NUMBER CODE:

DS1027 - X X X X X - N - 067

- PROFILE HEIGHT: 1:8.0mm
- CONTACT PLATING:
 - 2: GOLD+NICKEL
 - 8: GOLD FLASH
 - N: NICKEL
- HOUSING COLOR: B: BLACK
- HOUSING TYPE: A:OPEN TYPE
- No.OF CONTACTS: 2: 2pin
- SERIES No: DS1027

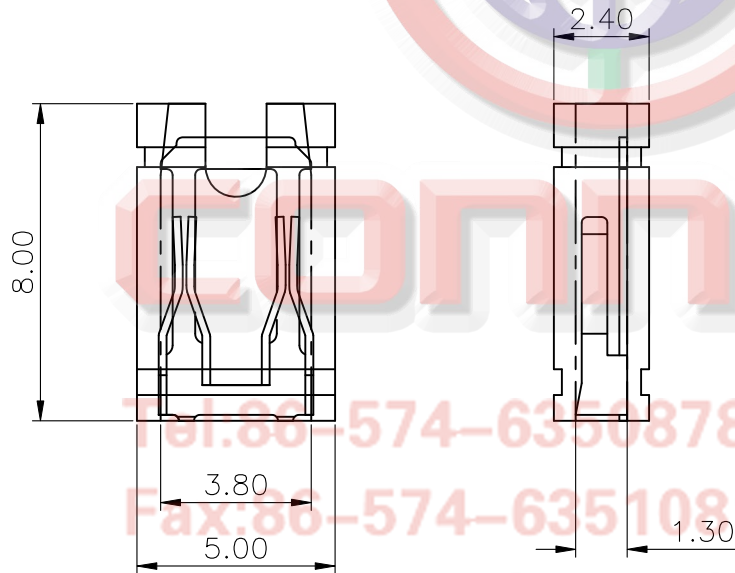

Tel:86-574-63508787
 Fax:86-574-63510817
 E-mail:sale@connfly.com
 http://www.connfly.com
 Add:East Industry Zone KuangYan
 Town Cixi Ningbo China
 P.C:315333

GENERAL TOLERANCE		ANGLE TOLERANCE	
X.	±0.60	X.	±5°
.X	±0.38	.X	±3°
.XX	±0.25	.XX	±2°
DRAWING TYPE		CUSTOMER	
SCALE	1:1	SHEET	1 OF 1
DRAWING NO.	C-DS1027-XXXXX-N-067		

PROJECTION	TITLE
	MINI JUMPER
UNITS	mm
SHEET SIZE	A4
SERIES	DS1027 SERIES

晨翔电子有限公司
CONNFLY CONNFLY ELECTRONIC CO. LTD