

未注公差/General tolerances(mm)											D 0.1/10			
0	>3	>6	>10	>18	>30	>50	>80	>120	>180	>250				
~3	~6	~10	~18	~30	~50	~80	~120	~180	~250	~315	~400	~500	~500	±2'
±0.12	±0.18	±0.22	±0.26	±0.31	±0.37	±0.57	±0.80	±0.93	±1.05	±1.15	±1.60	±2.20	±2.50	

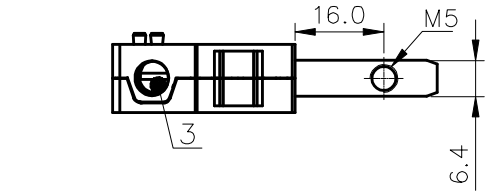

DGP16J-01P-1Y-00AH

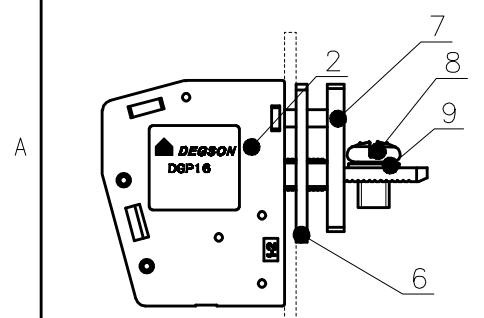
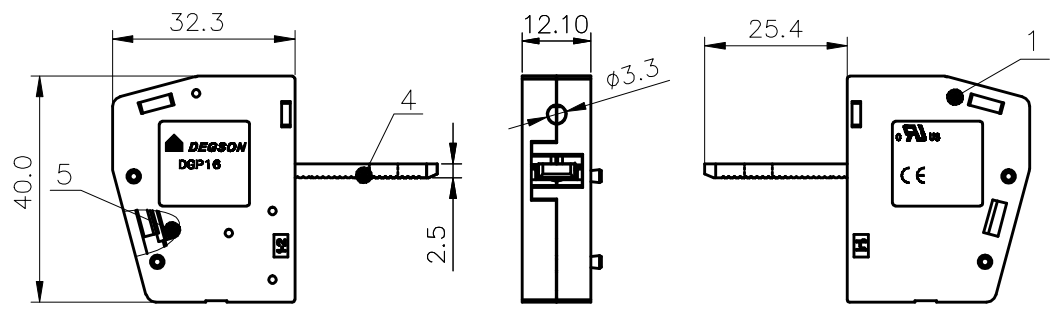

Board(1~6mm)

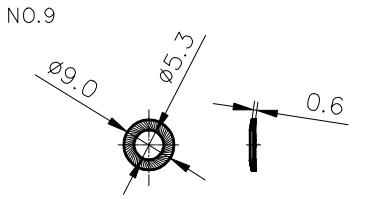
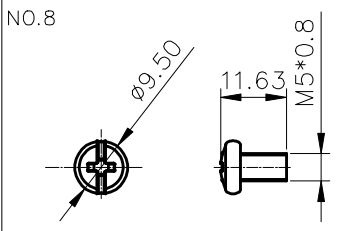
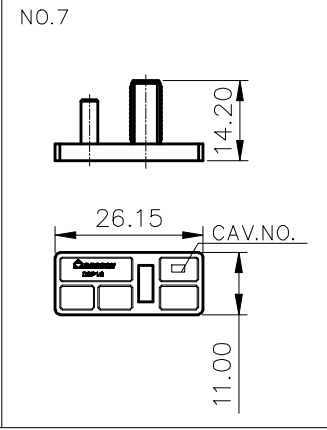
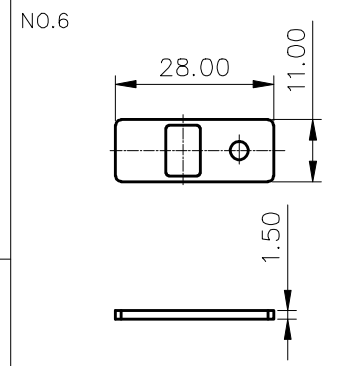
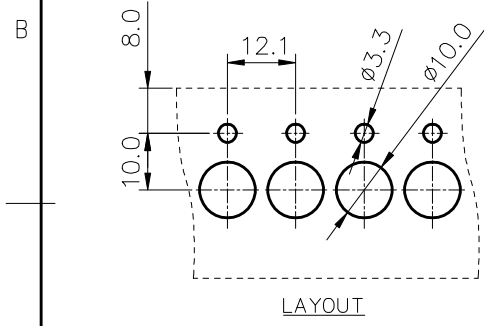

UL 标准/UL Standard:	B	C	D
额定电压/电流/Rated Voltage(V)/Current(A)	600/85	600/85	600/5
IEC 标准/IEC Standard:			
过压类别/Overvoltage Category/污染等级/Pollution Degree	III/3	III/2	II/2
额定电压/电流/Rated Voltage(V)/Current(A)	500/76	/	/
额定脉冲电压(kV)/Rate Impulse Voltage(kV)	6	/	/
螺丝扭矩/Torque Tightening(N·m/Lb.in)	M5, 2.0/17.54		
线径范围(硬线和软线)/Wire Range(rigid and flexible)(mm ² /AWG)	0.5~16/20~4		
间距/Pitch(mm)/线数范围/Poles	12.10/N=01P		
剥线长度/Stripping length(mm)	16		
使用温度范围/Operating temperature(°C)	-40~+105		
符合RoHS环保要求/Conform to RoHS	Yes		

ITEM	NAME OF PART	MATERIAL	NOTES
9	Lock Washer	Steel	Zn Plated
8	Screw2	Steel	Zn Plated
7	Housing3	PA66	UL94V-0
6	Antivibration Pad	EVA	Black
5	Cage	Copper alloy	Ni Plated
4	Current Carrier	Copper	Sn Plated
3	Screw1	Copper alloy	Sn Plated
2	Housing2	PA66	UL94V-0
1	Housing1	PA66	UL94V-0

REV	ECN	DESCRIPTION	DRFT	DATE

MATERIAL: /	SURFACE: /		
MAT NO.: /	宁波高松电子有限公司 NINGBO DEGSON ELECTRICAL CO., LTD		
STATUS: /			
APPD:	NAME: DGP16-01P-1Y-00A(H)		
CHKD:	DRAWING NO.: DGP16-C01		
DRFT: WWF 2015.05.31	REV	TO	
④ SIZE: A4	TYPE: CUSTOMER DRAWING	SCALE: 2:1	SHEET 1/1