

Pitch Range In mm			Nominal Dimension Range In mm					— ◡ ▽	
TO	Over	Over	TO	Over	Over	Over	Over	0.1/10	
6	6 TO 10	10 TO 24	30	30 TO 60	60 TO 100	100 TO 150	150		
±0.15	±0.20	±0.30	±0.30	±0.50	±0.70	±1.00	±1.30	±2'	

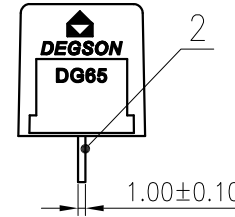
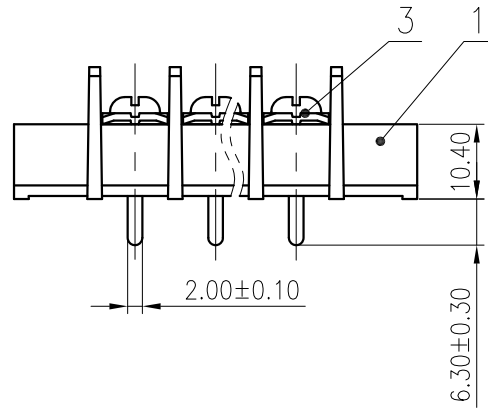
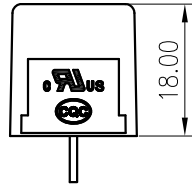
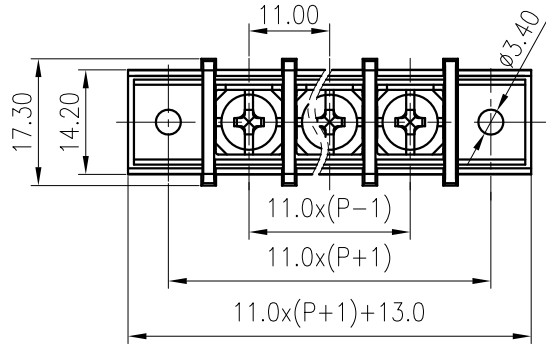

DG65C-A-XXP-1Y-00AH
DG65C-A - series
XXP - number of Poles (number of Pins)
1 - single-row
Y - color of housing (3 - black color)
00AH - no value

3	Screw	Steel	Ni Plated
2	Pin header	Copper alloy	Sn Plated
1	Housing	PA66	UL94V-0
ITEM	NAME OF PART	MATERIAL	NOTES

UL 标准/UL Standard:	B	C	D
额定电压/电流/Rated Voltage(V)/Current(A)	300/30	/	300/10
IEC 标准/IEC Standard:			
过压类别/Overvoltage Category/污染等级/Pollution Degree	III/3	III/2	II/2
额定电压/电流/Rated Voltage(V)/Current(A)	300/20	300/20	600/20
额定脉冲电压(KV)/Rate Impulse Voltage(KV)	4	4	4
螺丝扭矩/Torque Tightening(N·m/Lb.in)	M4, 1.2/10.53		
线径范围(软线)/Wire Range(flexible)(AWG)	22~10		
间距/Pitch(mm)/线数范围/Poles	11.00/N=02~20P		
剥线长度/Stripping length(mm)	10		
使用温度范围/Operating temperature(°C)	-40~+105		
符合RoHS环保要求/Conform to RoHS	Yes		

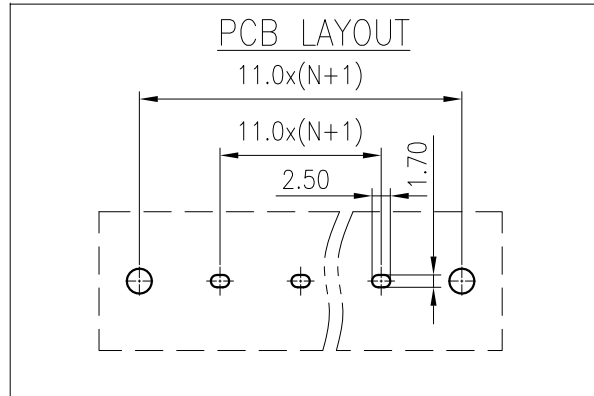

MATERIAL: /	SURFACE: /		
MAT NO.: /	宁波高松电子有限公司 NINGBO DEGSON ELECTRICAL CO., LTD		
STATUS: /			
APPD:	NAME: DG65C-A-XXP-1Y-00A(H)		
CHKD:	DRAWING NO.: DG65C-C03		
DRFT: Wu NK 2020.05.28	REV	TO	
REV	ECN	DESCRIPTION	DRFT
⊕	SIZE: A4	mm (inch)	TYPE: CUSTOMER DRAWING
		SCALE: 1:1	SHEET 1/1