

未注公差/General tolerances(mm)												0.1/10 ±2'	
0	>3	>6	>10	>18	>30	>50	>80	>120	>180	>250	>315		>400
~3	~6	~10	~18	~30	~50	~80	~120	~180	~250	~315	~400	~500	>500
±0.12	±0.18	±0.22	±0.26	±0.31	±0.37	±0.57	±0.80	±0.93	±1.05	±1.15	±1.60	±2.20	±2.50

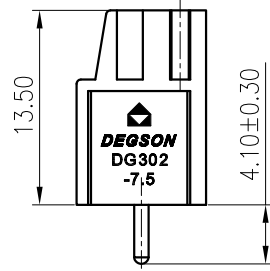
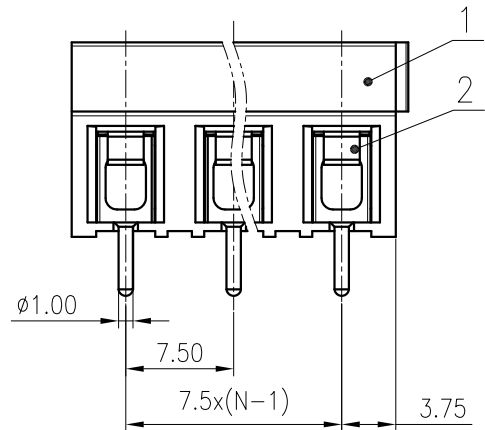
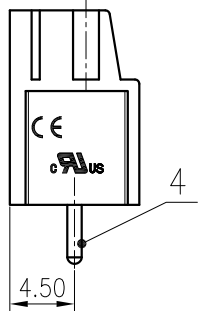
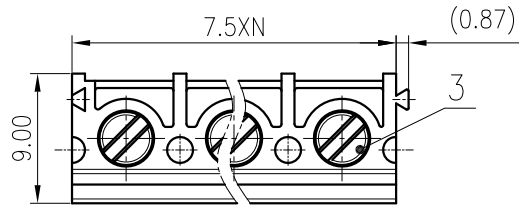

DG302-7.5-XXP-1Y-00AH
DG302-7.5 - series
XXP - number of Poles (number of Pins)
1 - single-row
Y - color of housing (4 - green color)
00AH - no value

4	Pin header	Copper alloy	Sn plated
3	Screw	Steel	M3/Zn plated
2	Spring	Stainless steel	
1	Housing	PA66	UL94V-0
ITEM	NAME OF PART	MATERIAL	NOTES

UL 标准/UL Standard:	B	C	D
额定电压/电流/Rated Voltage(V)/Current(A)	300/20	/	300/10
IEC 标准/IEC Standard:			
额定电压/电流/Rated Voltage(V)/Current(A)	450/25		
工频耐压/Withstanding voltage(V/1Min)	AC2500		
螺丝扭矩/Torque Tightening(N·m/Lb.in)	M3, 0.5/4.43		
线径范围(硬线和软线)/Wire Range(rigid and flexible)(mm ² /AWG)	0.5~4/20~12		
间距/Pitch(mm)/线数范围/Poles	7.5/N=02~16P		
剥线长度/Stripping length(mm)	6.5		
使用温度范围/Operating temperature(°C)	-40~+105		
符合RoHS环保要求/Conform to RoHS	Yes		

PCB LAYOUT

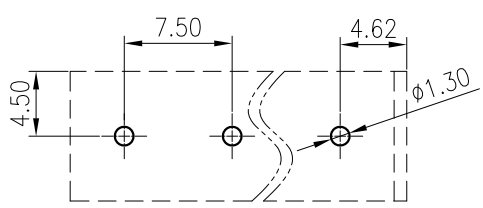

MATERIAL: /	SURFACE: /		
MAT NO.: /	宁波高松电子有限公司 NINGBO DEGSON ELECTRICAL CO., LTD		
STATUS: /			
APPD: LanChH 2020.05.20	NAME: DG302-7.5-XXP-1Y-00A(H)		
CHKD: YuJZ 2020.05.20	DRAWING NO.: 10001994		
DRFT: ChenZh 2020.05.20	REV: TO		T0
SIZE: A4	TYPE: CUSTOMER DRAWING	SCALE: 2:1	SHEET 1/1

REV	ECN	DESCRIPTION	DRFT	DATE