

REVISION RECORD				
REV	ECN	DESCRIPTION	DRFT	DATE

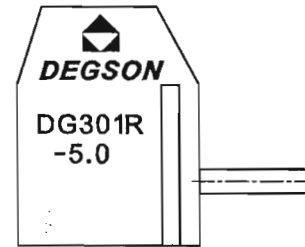
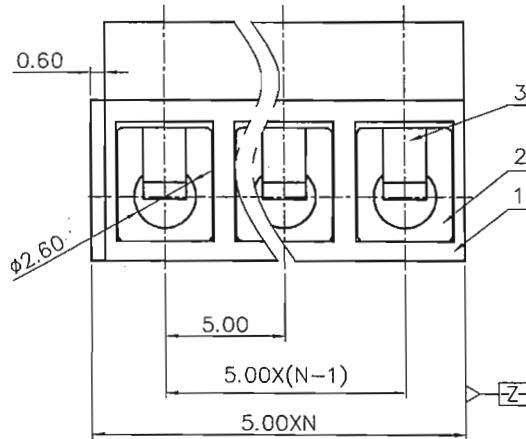
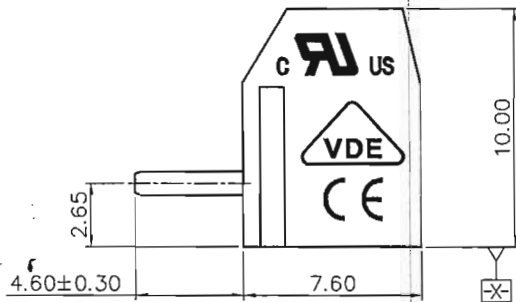
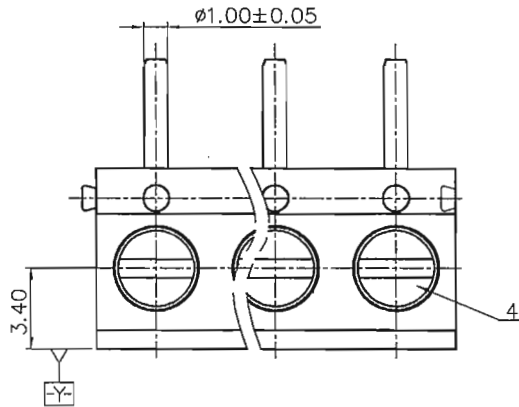

NOTES1:

- UL Standard
- 1. Rated Voltage/Current : 300V / 15A
- 2. Torque Value : M2.5 , 3.54Lb.in
- 3. Wire Range : 22~14AWG

IEC Standard

- 1. Rated Voltage/Current : 250V / 17.5A
- 2. Torque Value : M2.5 , 0.4N.m
- 3. Wire Range : 0.2~1.5mm²

NOTES2:

- 1. Dimension shall be interpreted per ASME Y14.5-2009
- 2. Pitch : 5.0mm, Poles : N=02~22P
- 3. Stripping length : 5~6mm
- 4. Withstanding Voltage : AC2000V/1Min.
- 5. Operating temperature : -30°C~+120°C
- 6. Undimensioned Tolerances:

Pitch Range In mm		Nominal Dimension Range In mm				
TO	Over TO	TO	Over TO	TO	Over TO	0.1/10
6	10	24	30	60	100	<
±0.15	±0.20	±0.30	±0.50	±0.75	±1.00	±2'

7. RoHS Compliance

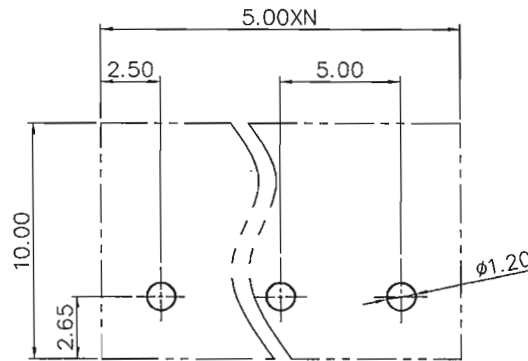

P.C.B. LAYOUT

ITEM	NAME OF PART	MATERIAL	NOTES
4	SCREW	STEEL	Zn plated
3	SPRING	STAINLESS STEEL	
2	PIN HEADER	PHOSPHOR BRONZE	Sn plated
1	HOUSING	PBT	UL94V-0

DETACHED LISTS	PART NO.:	宁波高松电子有限公司 DEGSON [®] NINGBO DEGSON ELECTRICAL CO., LTD		
	APPD: <i>Aaxon Flg-15</i>	NAME: DG301R-5.0-XXP-1Y-00A(H)		
	CHKD: <i>Jh 9/8 '15</i>	TITLE: CUSTOMER DRAWING		
	DRFT: Haoyh 03/20/06"	REV	TO	
 THIRD ANGLE PROJECTION		DRAWING NO.: DG301R-C02	SHEET	1/1
 DO NOT SCALE DRAWING		SCALE	1:1	