

TO	Pitch Range In mm		Nominal Dimension Range In mm				0.1/10
	Over 6 TO	Over 10 TO	Over 30 TO	Over 60 TO	Over 100 TO	Over 150 TO	
6	±0.20	±0.30	±0.30	±0.50	±0.70	±1.00	±2'

A

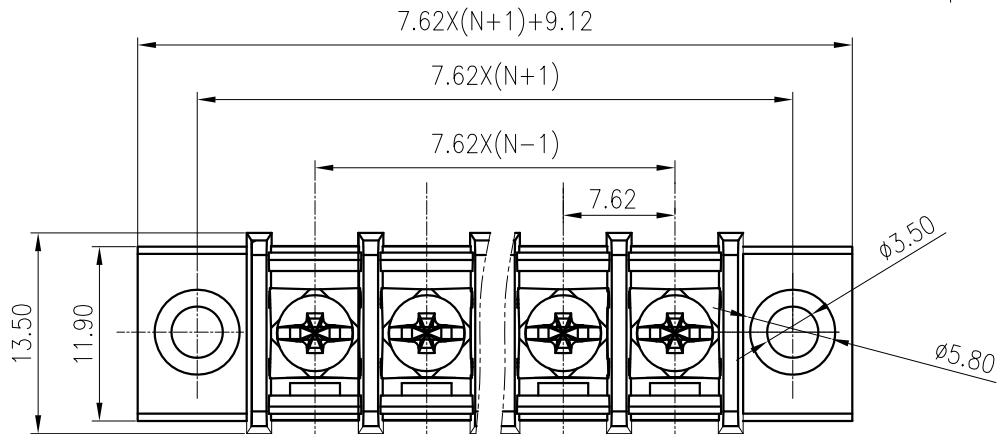

B

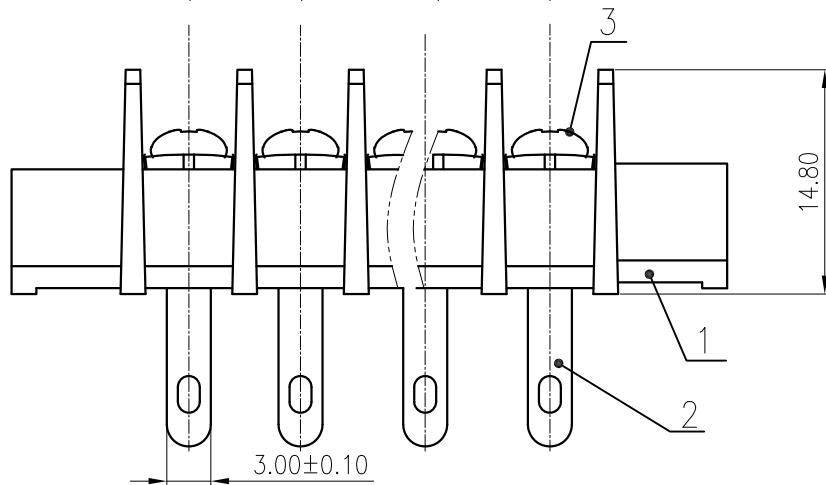

C

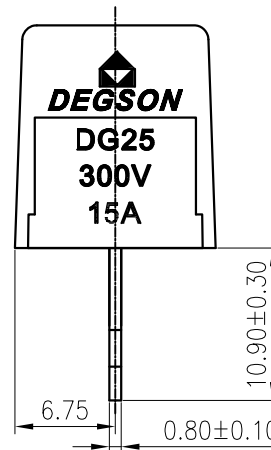

DG25H-A-XXP-1Y-00AH
DG25H-A - series
XXP - number of Poles (number of Pins)
1 - single-row
Y - color of housing (3 - black color)
00AH - no value

ITEM	NAME OF PART	MATERIAL	NOTES
3	SCERW	STEEL	Ni PLATED
2	PIN HEADER	COPPER ALLOY	Sn PLATED
1	HOUSING	PA66	UL94V-0
UL 标准/UL Standard: B C D			
额定电压/电流/Rated Voltage(V)/Current(A) 300/15 300/10			
IEC 标准/IEC Standard:			
过压类别/Overvoltage Category/污染等级/Pollution Degree III/3 III/2 II/2			
额定电压/电流/Rated Voltage(V)/Current(A) 300/24 300/24 600/24			
额定脉冲电压(KV)/Rate Impulse Voltage(KV) 5 5 5			
螺丝扭矩/Torque Tightening(N·m/Lb.in) M3, 0.5/4.43			
线径范围/Wire Range(AWG) 22~14AWG			
间距/Pitch(mm)/线数范围/Poles 7.62/N=02~24P			
剥线长度/Stripping length(mm) 7			
使用温度范围/Operating temperature(°C) -40~+105			
符合RoHS环保要求/Conform to RoHS Yes			

A

B

C

D

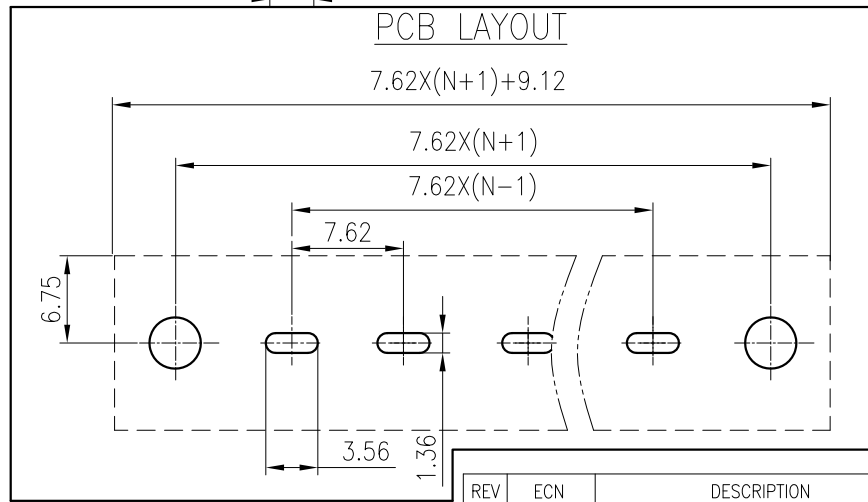

MATERIAL: /	SURFACE: /		
MAT NO.: /	宁波高松电子有限公司 NINGBO DEGSON ELECTRICAL CO., LTD		
STATUS: /	NAME: DG25H-A-XXP-1Y-00A(H)		
APPD:	DRAWING NO.: DG25H-C03 REV TO		
CHKD:	TYPE: CUSTOMER DRAWING SCALE: 2:1 SHEET 1/1		
DRFT: ZhangJ 2020.05.22			

REV	ECN	DESCRIPTION	DRFT	DATE

SIZE: A4 mm (inch)