

REVISION RECORD					
REV	ECN	DESCRIPTION	DRFT	DATE	
△		更改电流参数	HYQ	06/09/09"	
△	14-0025	依实物修改图纸	ZDZ	01/10/14"	

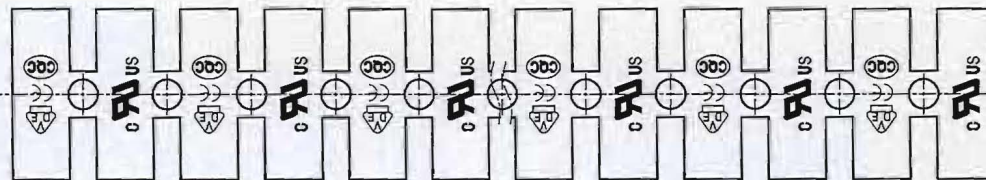
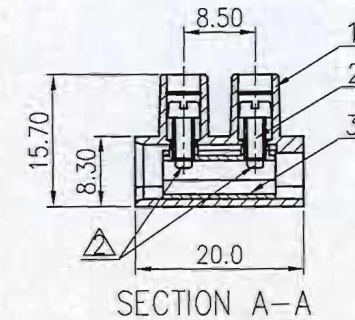
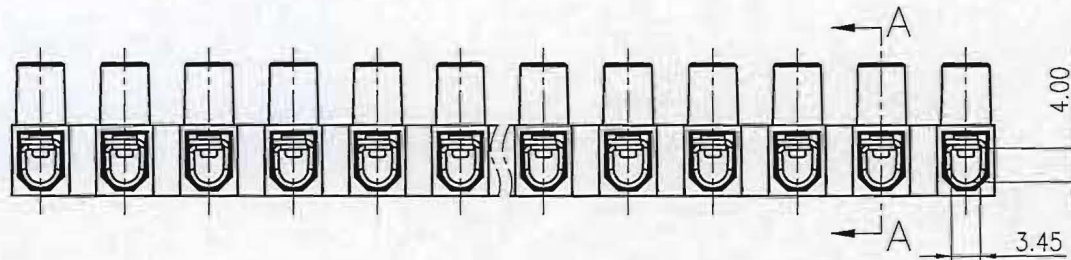
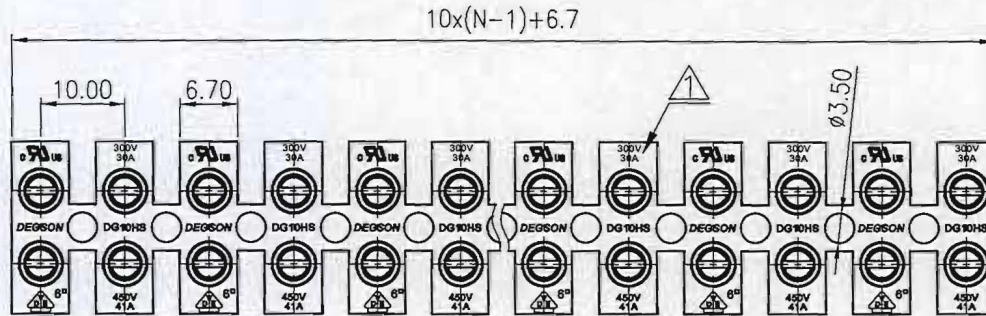

文档中心
研发专用
2013.11.30
(仅限内部使用, 对外无效)

NOTES:

1. DIMENSION SHALL BE INTERPRETED PER ASME Y14.5-2009.
2. PITCH: 10.0MM, POLES: 02-12P, N=POLES
3. RATED VOLTAGE/CURRENT: UL 300V 30A △
VDE 450V 41A
4. OPERATION TEMPERATURES: -40°C~+105°C
5. WITHSTANDING VOLTAGE: AC2000V/1MIN.
6. INSULATION RESISTANCE: 5000MΩ/DC1000V
7. WIRE RANGE: 18-12AWG; 1-6mm²
8. MAX. TORQUE VALUE: M3.0, 5.10kgf.cm
9. UNDIMENSIONED TOLERANCES:

PITCH RANGE IN MM		NOMINAL DIMENSION RANGE IN MM					
OVER 6 TO 10	OVER 10 TO 24	TO 30	OVER 30 TO 60	OVER 60 TO 100	OVER 100 TO 150	OVER 150	□
±0.10	±0.15	±0.25	±0.20	±0.30	±0.50	±0.70	±1.00
							0.05/10

ITEM	NAME OF PART	NO. OF PART	Q"TY	MATERIAL	NOTES
3	DG10HS-Current carrier	X000002130(H)	XX	Steel	Cr ³⁺ Zn
2	DG10H"-Screws	S000003000(H)	XX*2	Steel	Cr ³⁺ Zn
1	DG10HS-0 Housing	2029A0YXXA(H)	1	PA66	UL94V-2

DETACHED LISTS		MATERIAL:		FINISH:	
TOLERANCES EXCEPT AS NOTED		PART NO.:		NAME:	
.X ±	.X' ±			DG10HS-0-XXP-1Y-100A(H)	
.XX ±	.XX' ±				
.XXX ±	.XXX' ±				
ANGLES ± 1°		APPD: <i>ZhuWenJun</i>		TITLE: ASSEMBLY DRAWING	
THIRD ANGLE PROJECTION		CHKD: <i>CAOLB 2019-11-16</i>		DRAWING NO.: DG10HS-0-E02	
		DRFT: ZDZ 01/10/14"		DO NOT SCALE DRAWING	
				SCALE	N/A
				SHEET	1/1