

△ Recommended P.C.B. Layout

△ SPECIFICATION
 Current Rating:3 Amp
 Voltage Rating:250V AC/RMS 60Hz
 Contact Resistance:20 Milliohms Max. At 1 Amp DC
 Insulation Resistance:1000 Megaohms Min. At 500V DC
 Withstanding Resistance:1000V AC/RMS 60Hz For 1 Minute
 Insulator:PBT+30%G.F.(UL94V-0),Black
 Contact:Brass,Selective Gold Flash
 Shell:Steel,Tin Plated Over Copper
 Boardlock:Brass,Tin Plated
 Screw:Brass,Nickel Plated
 RoHS Compliant

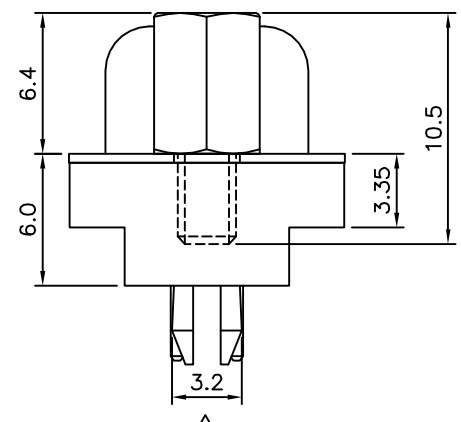
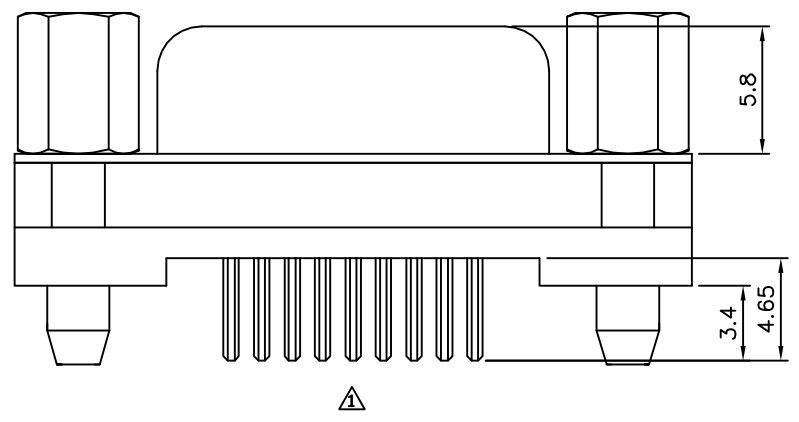
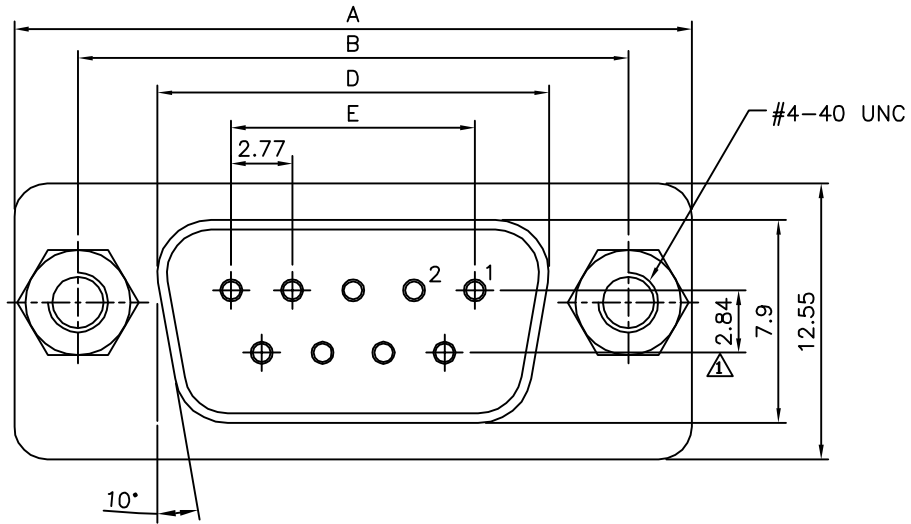

△

Pin	A	B	D	E
09	30.81	24.99	16.33	11.08
15	39.20	33.30	24.70	19.39
25	53.05	47.04	38.40	33.24
37	69.40	63.50	54.80	49.86

AUK A MEMBER OF AUK GROUP
太聯事業股份有限公司
AUK CONTRACTORS CO., LTD.

CATEGORY		APPROVED BY		UNLESS OTHERWISE SPECIFIED TOLERANCES ARE .X ±0.38 X.* ±3* .XX ±0.25 .X.* ±1.0* .XXX ±0.13
PART No. DDMXXSZJ-H		MEI		
DRAWING No. DDMXXSZJ-H		CHECKED BY HZF		
SCALE NONE		DRAWING BY WSS		
REV.	B1	UNIT mm		

NO.	REV.	REVISIONS	CHK	DATE
△ B1		Modify Data	HZF	07/15/2011
△ B0		NEW RELEASE	BECKY	06/06/2006