

REVISION RECORD				
REV	ECN	DESCRIPTION	DRFT	DATE

NOTES1:

UL Standard

1. Rated Voltage/Current : 600V / 50A
2. Withstanding Voltage : AC2200V/1Min.
3. Torque Value : M4 , 10.53Lb.in
4. Wire Range : 26~12AWG

IEC Standard

1.

Pollution Degree	3
Overvoltage Category	III
Rate Impulse Voltage(KV)	8.0KV
Rate Voltage(V)	1000V
Rate Current(A)	41A

2. Torque Value : M4 , 1.2N.m
3. Wire Range : 0.5~6mm²

NOTES2:

1. Dimension shall be interpreted per ASME Y14.5-2009
2. Pitch : 8.0mm, Poles : 01P
3. Stripping length : 10-12mm
4. Operating temperature: -40°C~+105°C
5. Undimensioned Tolerances:

Pitch Range In mm	Nominal Dimension Range In mm						0.1/10	
	Over 6 TO 10	Over 10 TO 24	Over 30 TO 60	Over 60 TO 100	Over 100 TO 150	Over 150		
±0.15	±0.20	±0.30	±0.30	±0.50	±0.70	±1.00	±1.30	±2°

6. RoHS Compliance

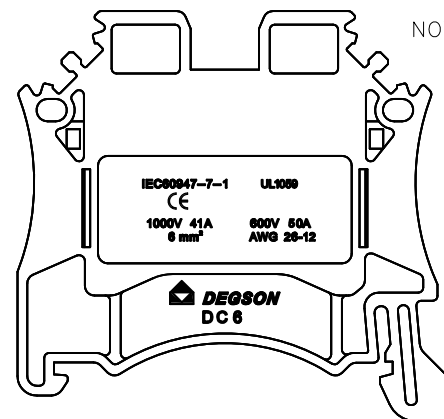
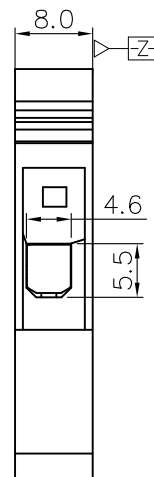
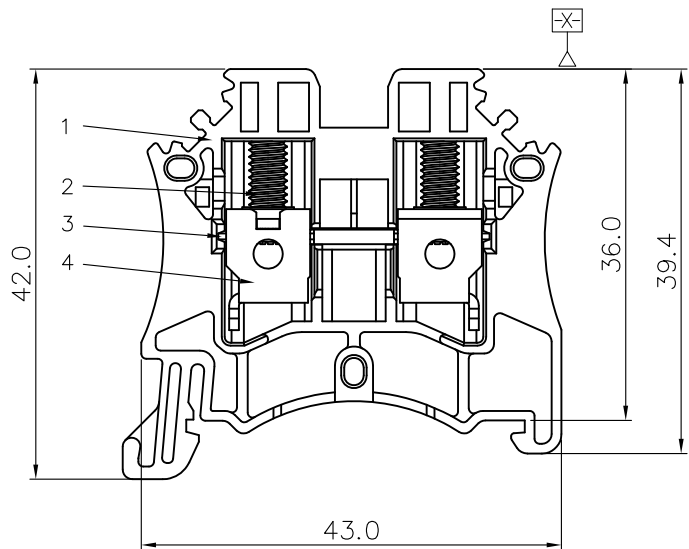
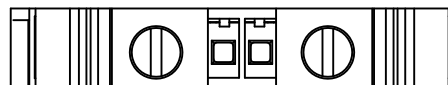

DC6-01P-1Y-00AH

DC6 - series

Y = 1 (Grey color of Housing)

4	GAGE	2	STEEL	M4/Zn PLATED
3	CURRENT CARRIER	1	COPPER ALLOY	Sn PLATED
2	SCREW	2	STEEL	M4/Zn PLATED
1	HOUSING	1	PA66	UL94V-0
ITEM	NAME OF PART	Q'TY	MATERIAL	NOTES

DETACHED LISTS	PART NO.:	/		
	APPD:	NAME: DEGSON ® NINGBO DEGSON ELECTRICAL CO., LTD		
	CHKD:	DC6-01P-1Y-00A(H)		
	DRFT: ding 2015/10/29	TITLE: CUSTOMER DRAWING	REV	D0-1
	DRAWING NO.: DC6-C01		SHEET	1/1
THIRD ANGLE PROJECTION		MM (INCH)	DO NOT SCALE DRAWING	SCALE 1:1