

REVISION RECORD				
REV	ECN	DESCRIPTION	DRFT	DATE

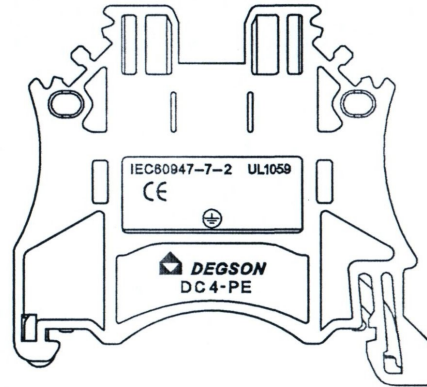
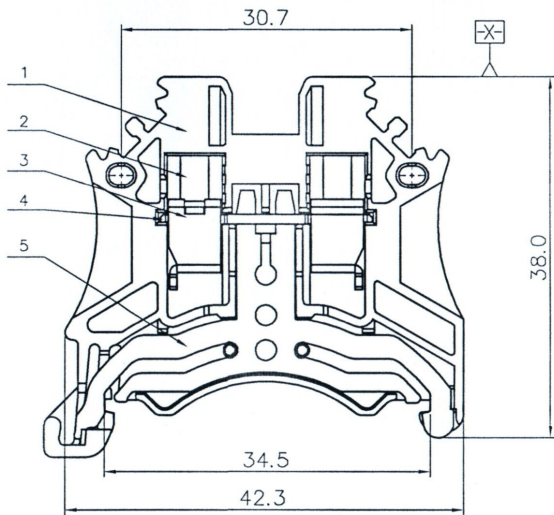
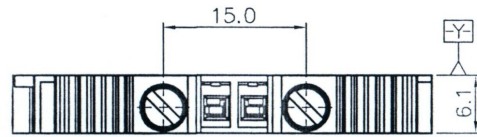

NOTES1:

UL Standard

- 1.Torque value : M3 , 6.0Lb.in
- 2.Wire range : 22~10AWG

IEC Standard

1. Pollution degree	3
Overvoltage category	III
Rate impulse voltage(KV)	/
Rate voltage(V)	/ V
Rate current(A)	/ A

- 2.Torque value : M3 , 0.5N·m
- 3.Wire range : 0.5~4mm²

NOTES2:

- 1.Dimension shall be interpreted per ASME Y14.5-2009
- 2.Stripping length : 8~9mm
- 3.Operating temperature: -40°C~+105°C
- 4.Undimensioned tolerances:

Pitch Range In mm	Nominal Dimension Range In mm							0.1/10	
	Over 6 TO 10	Over 10 TO 24	Over 30 TO 30	Over 60 TO 60	Over 100 TO 150	Over 150			
	±0.15	±0.20	±0.30	±0.30	±0.50	±0.70	±1.00	±1.30	±2*

5.RoHS Compliance

DC4-PE-01P-1C-00AH

DC4-PE - series

1 - single-row

C - color of housing (yellow-green color)

00AH - no value

Rated surge voltage 1000 volts

仅供參考圖
 签字:
 2016.07.14

5	CURRENT CONTACT	COPPER ALLOY	Sn PLATED
4	CURRENT CARRIER	COPPER	Sn PLATED
3	CAGE	STEEL	M3/Zn PLATED
2	SCREW	STEEL	M3/Zn PLATED
1	HOUSING	PA66	UL94V-0
ITEM	NAME OF PART	MATERIAL	NOTES

DETACHED LISTS	PART NO.:	NINGBO DEGSON ELECTRICAL CO., LTD		
	APPD: Alan 07/14/16"	NAME: DC4-PE-01P-1C-00A(H)		
	CHKD:	TITLE: CUSTOMER DRAWING		
	DRFT: XMY 10/28/15"	DRAWING NO.:	DC4-PE-C01	REV: D0-1
	THIRD ANGLE PROJECTION	DO NOT SCALE DRAWING	SHEET: 1/1	SCALE: 1:1

H
G
F
E
D
C
B
A

H
G
F
E
D
C
B
A