

REVISION RECORD				
REV	ECN	DESCRIPTION	DRFT	DATE

NOTES1:
 UL Standard
 1.Torque value : M2.5 , 5.0Lb.in
 2.Wire range : 26~12AWG

IEC Standard

1.

Pollution degree	3
Overtoltage category	III
Rate impulse voltage(KV)	/
Rate voltage(V)	/ V
Rate current(A)	/ A

2.Torque value : M2.5 , 0.4N·m
 3.Wire range : 0.2~2.5mm?

NOTES2:
 1.Dimension shall be interpreted per ASME Y14.5-2009
 2.Stripping length : 8~9mm
 3.Operating temperature: -40°C~+105°C
 4.Undimensioned tolerances:

Pitch		Range In		Nominal Dimension Range				D
mm	In	In	mm	In	mm	In		
TO	TO	Over 6 TO 10	Over 10 TO 24	Over 30 TO 60	Over 60 TO 100	Over 100 TO 150	Over 150	0.1/10
6	10	10	24	30	60	100	150	<
±0.15	±0.20	±0.30	±0.30	±0.50	±0.70	±1.00	±1.30	±2'

5.RoHS Compliance

ITEM	NAME OF PART	MATERIAL	NOTES
5	GROUNDING	PHOSPHOR BRONZE	Zn Plated
4	CAGE	STEEL	M2.5/Zn Plated
3	CURRENT CARRIER	COPPER	Zn Plated
2	SCREW	STEEL	M2.5/Zn Plated
1	HOUSING	PA66	UL94V-0

PART NO.: /		宁波高松电子有限公司 NINGBO DEGSON ELECTRICAL CO., LTD	
APPD: <i>Almo/14/16'</i>		NAME: DC2.5-PE-01P-1C-00A(H)	
CHKD:		TITLE: CUSTOMER DRAWING	
DRFT: XMY 1/29/16"		REV: D0-1	DO-1
THIRD ANGLE PROJECTION		DRAWING NO.: DC2.5-PE-C01	SHEET 1/1
DO NOT SCALE DRAWING		SCALE: 1:1	

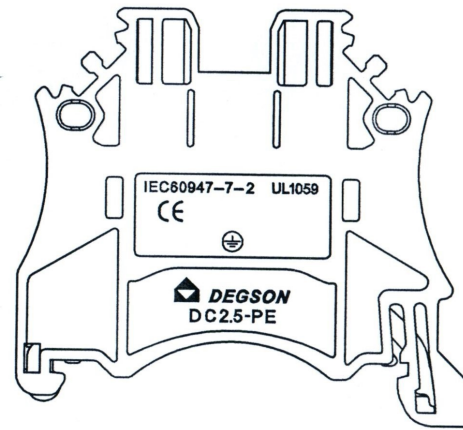
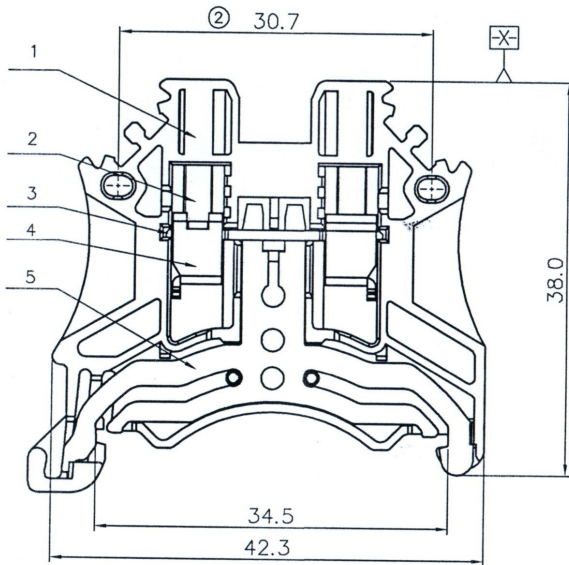
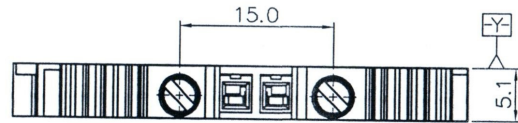

DC2.5-PE-01P-1C-00AH
 DC2.5-PE - series
 1 - single-row
 C - color of hosing (yellow-green color)
 00AH - no value
 Rated surge voltage 1000 volts

仅供参考图

日期: *2016.07.14*

H
G
F
E
D
C
B
A