

REVISION RECORD				
REV	ECN	DESCRIPTION	DRFT	DATE

NOTES1:

- UL Standard
1. Rated voltage/current : 600V / 25A
 2. Withstanding voltage : AC2200V/1Min.
 3. Torque value : M2.5 , 3.54Lb.in
 4. Wire range : 26~12AWG

IEC Standard

1.

Pollution degree	3
Overtoltage category	III
Rate impulse voltage(KV)	8.0KV
Rate voltage(V)	800 V
Rate current(A)	24A
2. Torque value : M2.5 , 0.4N·m
3. Wire range : 0.2~2.5mm²

NOTES2:

1. Dimension shall be interpreted per ASME Y14.5-2009
2. Pitch : 5.10mm, Poles : 01P
3. Stripping length : 8~9mm
4. Operating temperature: -40°C~+105°C
5. Undimensioned tolerances:

Pitch Range In mm		Nominal Dimension Range In mm					0.1/10
TO	Over TO	TO	Over TO	Over TO	Over TO		
6	10	30	60	100	150	±2'	
±0.15	±0.20	±0.30	±0.30	±0.50	±0.70		

6. RoHS Compliance

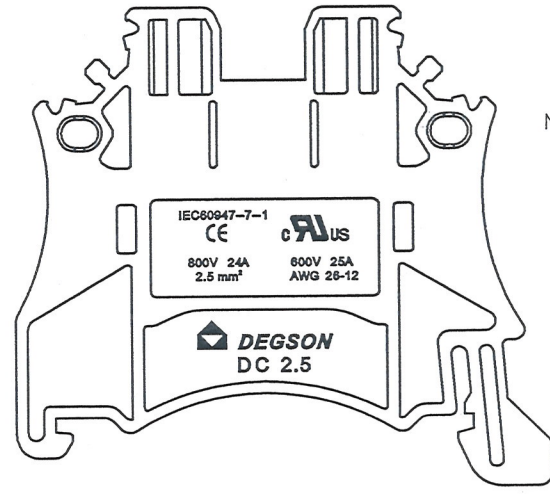
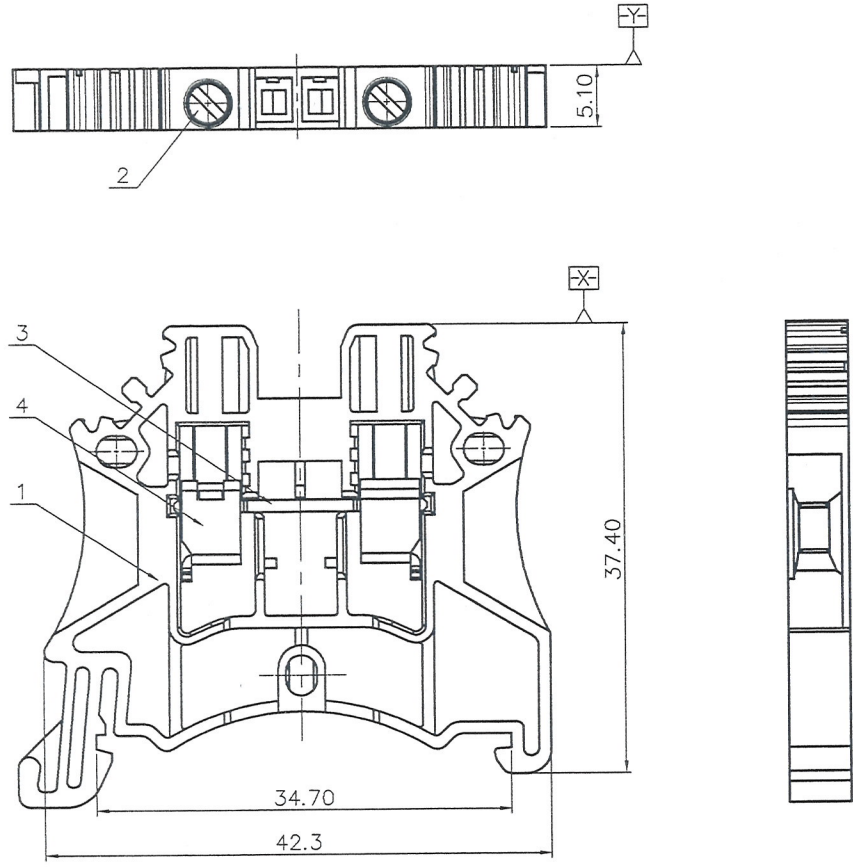

DC2.5 - 01P - 1Y - 00A (H)
 (Series No.) (Poles) (Single Pitch) (Color) (RoHS)
 00A-(Standard)
 1.(Grey)
 2.(Blue)
 3.(Black)
 4.(Green)
 5.(Orange)
 6.(Red)
 7.(Transparent)
 8.(Yellow)
 9.(White)

文策零備
2018.4.28

ITEM	NAME OF PART	MATERIAL	NOTES
4	Cage	Steel	M2.5/Zn plated
3	Current carrier	Copper alloy	Sn Plated
2	Screw	Steel	M2.5/Zn plated
1	Housing	PA66	UL94V-0

DETACHED LISTS	PART NO.: Series DC2.5	宁波高松电子有限公司 NINGBO DEGSON ELECTRICAL CO., LTD		
	APPD: <i>Arson 2018.4.25</i>	NAME: DC2.5-01P-1Y-00A(H)		
	CHKD: <i>dyz 2018.4.25</i>	DRFT: ding 2015.10.24		
	THIRD ANGLE PROJECTION		TITLE: CUSTOMER DRAWING	REV TO
	DRAWING NO.: DC2.5-C01		SHEET 1/1	SCALE 1:1