

REVISION RECORD

REV	ECN	DESCRIPTION	DRFT	DATE
-----	-----	-------------	------	------

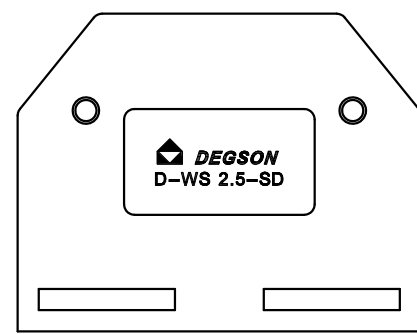
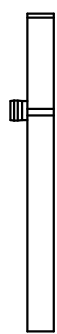
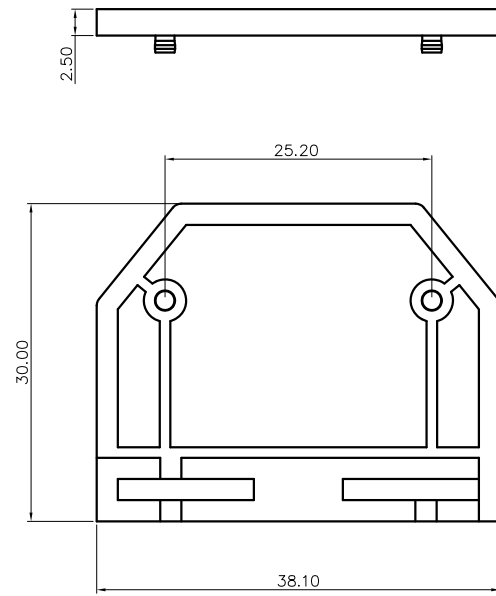

NOTES:

- 1.Dimension shall be interpreted per ASME Y14.5-2009
- 2.Pitch : 2.5mm, Poles : N=01P
- 3.Operating temperature:-40°C~+105°C
- 4.Undimensioned tolerances:

Pitch range in mm		Nominal dimension range in mm				-	∩	□
TO 6	Over 6 TO 10	Over 10 TO 24	TO 30	Over 30 TO 60	Over 60 TO 100	Over 100 TO 150	0.1/10	<
±0.15	±0.20	±0.30	±0.30	±0.50	±0.70	±1.00	±1.30	±2*

5.RoHS Compliance

D-WS2.5-SD - 01P - 1Y - 00A (H)
 (Series No.) (Poles) (Single Pitch) (Color):1.(Grey)
 2.(Blue)
 3.(Black)
 4.(Green)
 5.(Orange)
 6.(Red)
 7.(Transparent)
 8.(Yellow)
 9.(White)
 (RoHS)
 00A-(Standard)

Cover material: PA66 UL94V-0

DETACHED LISTS	PART NO.:	宁波高松电子有限公司 NINGBO DEGSON ELECTRICAL CO., LTD			
	APPD:	NAME: D-WS2.5-SD-01P-1Y-00A(H)			
	CHKD:	TITLE: CUSTOMER DRAWING			
	DRFT:	DRAWING NO.:		REV	DO
	THIRD ANGLE PROJECTION		MM (INCH)	DO NOT SCALE DRAWING	SCALE 1:1