**Constant Voltage Driver**
**Model:CV60W24CG-4**

Model	Rated Input Voltage	Input Power	Input Current	PF	Output Power Range	Output Voltage	Output Current	Efficiency (typ.)	Cementing product
CV60W24CG-4	220-240VAC	≤70W	≤0.35A	≥0.95	60W	24V	2.5A	89%	Y

\* Test result @230V, 50Hz, Full Load.

\* Recommended minimum power is 5% load.

**1. Parameters**

category	Item	Technical Norm			
Features	Output Type	Constant Voltage			
	Dimmable Type	Non-dimmable			
	Output Features	Isolation SELV			
	IP Grade	IP20			
	Insulation Class	Class II			
Input	Rated Input Voltage	220-240VAC			
	Range of AC Input Voltage	198-264VAC			
	Frequency	Rate:50/60Hz, Range:47~63Hz			
	Power Factor	≥0.95, 220-240VAC, Rated Load, see graphs >0.9 ,230VAC 40% Load			
	THD	≤10% ≤20%	230VAC, Rated Load, see graphs 230VAC 30% Load		
	No Load Power Consumption	≤0.5W, @230VAC,NO Load			
	Inrush Current	≤55A/350us (230VAC, full load)			
Output	Output Voltage	22.8-25.2VDC			
	No load Voltage	24-25.5VDC			
	Output Voltage Ripple	<2% Vp-p			
	Line Regulation	≤1%			
	Load Regulation	≤2%			
	filcker	SVM ≤0.4, PstLM ≤1.0			
	Start-up Time	≤0.5S (220-240VAC) Full load			
	Rise Time	17.6mS (typ.) (220-240VAC) Full load			
	Hold-up time & Turn off time (Typical)	Model	Hold-up time(mS)	Turn-off time(mS)	230VAC, LED Rated Load, Hold-up time measure from AC input turn-off to output voltage drop to 90%, turn-off time measure from
		60W	32	40	

					AC input turn-off to output voltage drop to 10%
	Efficiency	60W	≥88%	89% typ.	230VAC, Rated Load, at output terminals, see graphs
Protection	Short Circuit Protection	Auto Recovery			
	Over Current Protection	Auto Recovery			
	Over Voltage Protection	Auto Recovery			
	Insulation voltage	I/P to O/P, 3.75KVac/5mA/1min			
	Insulation resistance	>100M ohm @ 500VDC			
	Leakage current	I/P to O/P < 250µA			
Environment	Ta/Operation Temperature	-20....+50°C			
	Ts/Storage Temperature	-25....+85°C			
	Tc/Enclosure Temperature For Safety	90°C			
	Humidity	5%-95%Storage , 10%-90% Operation			
	Atmosphere	86-108KPa			
Construction	Connection Method	Terminal			
	Cable Terminals	PRI	1 terminal block(L, N)		
		SEC	1 terminals block(LED+,LED-)		
	Installation	Independent			
	PRI Wire Cross Section	0.75mm <sup>2</sup> -2.5 mm <sup>2</sup> wire prepatation 6~7mm			
	SEC Wire Cross Section	0.5mm <sup>2</sup> -2.5 mm <sup>2</sup> wire prepatation 6~7mm			
	SEC Cable Length	Max. 3M			
	Cable diameters range	PRI	3-10mm		
		SEC	3-10mm		
Dimension	60W	151.5*40.2*31mm (L*W*H)			
Standards	Certification	ENEC CCC UKCA SAA CB CE EAC			
	Safety Standards	EN 61347-1:2015/A1:2021;EN 61347-2-13:2014/A1:2017 EN IEC 62384:2020;EN 62493:2015/A1:2022 AS61347.2.13:2018;AS/NZS61347.1:2016 Inc A1 GB 19510.1-2009;GB 19510.14-2009;GB 19510.1-2023 GB 19510.213-2023,BS EN 61347-1:2015/A1:2021 BS EN 61347-2-13:2014/A1:2017,BS EN 62493:2015 BS EN IEC 62384:2020			
	EMC Standards	EN IEC 55015:2019,EN IEC 61547:2023 EN IEC 55015:2019/A11:2020 EN IEC 61000-3-2:2019/A1:2021 EN 61000-3-3:2013/A2:2021 BS EN IEC 55015:2019 BS EN IEC 55015:2019+A11:2020 BS EN IEC 61000-3-2:2019/A1:2021 BS EN 61000-3-3:2013+A2:2021 BS EN IEC 61547:2023			
	Performance	EN62384:2020			
	Surge	L-N:2KV; L,N-PE:1KV			
Others	RoHS .Reach	2011/65/EU .EU Regulation (EC) No 1907/2006			
	Audible Noise	<20dB @ 20cm distance, 14±1dB background			
		60W	≥50K Hrs		

Life Time		90°C@tc	@230VAC , full load, see graphs. End of Life: Failure Rate<10%.
Warranty	5years		

**Remark:**

1. All Parameters, if not specified, are measured at 230VAC/50Hz and 25°C ambient temperature.
2. LED Driver is a component of the luminaires, Luminaires and wire layout will affect the EMC, please check the EMC with end products again.
3. Output ripple should be measured at the output end which has with 0.1uF/50V ceramic capacitance and 47uF/50V Aluminum capacitance connected in parallel. Measured using oscilloscope with bandwidth limited to 20MHz.

### 2. Connected quantities of different current Breaker

TYPE	Connected quantities of different current Breaker						Input Voltage	Inrush Current (A)	Time (μ)
	current (A)	10	13	16	20	25			
	Installation wire diameter	1.5mm <sup>2</sup>	2.5mm <sup>2</sup>	2.5mm <sup>2</sup>	4mm <sup>2</sup>	4mm <sup>2</sup>			
TYPE B		13	17	21	27	33	@230VAC	45	300
TYPE C		21	28	34	43	53			
TYPE D		34	44	55	68	85			

### 3. Label



LED Driver LED控制装置  
**CV60W24CG-4**  
Constant Voltage Type for LED Only

wire preparation  
6mm PRI 0.75-2.5<sup>□</sup>  
SEC 0.5-2.5<sup>□</sup>

N PRI  
 L ?

Un= 220-240VAC  
IN= 0.35A Max.  
fn= 50/60Hz  
PF≥0.95

Urated=24VDC const.  
Irated= 2500mA Max.  
Prated= 60W Max.  
ta:-20°C...50°C tc:90°C Uout=25VDC Max.

•tc

**SELV** SEC+  
SEC I

M M













**Note: laser engraving.**

## 4. Graph

PF VS LOAD Curve

THD VS LOAD Curve

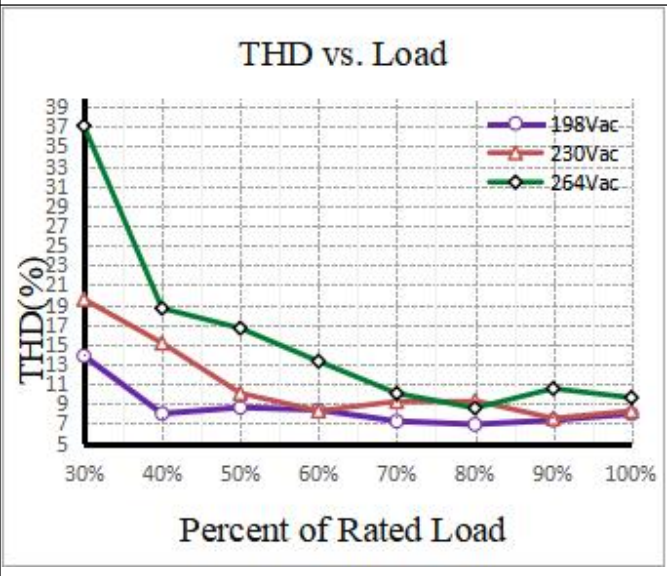
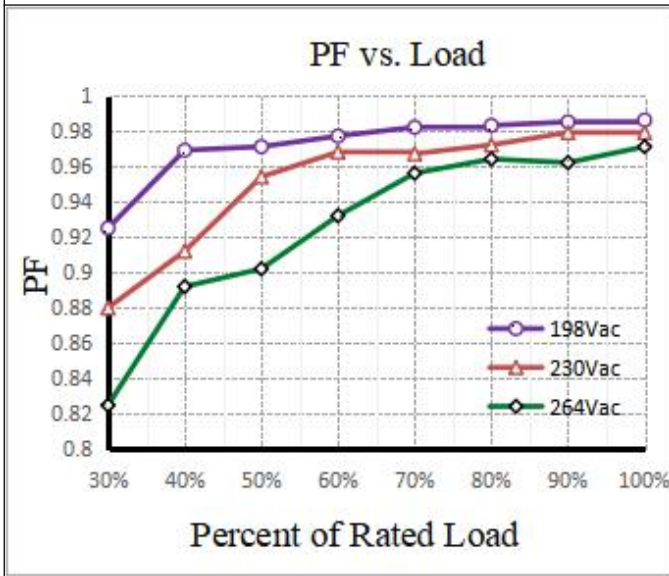

Efficiency VS LOAD Curve

Vout vs. Temperature Curve

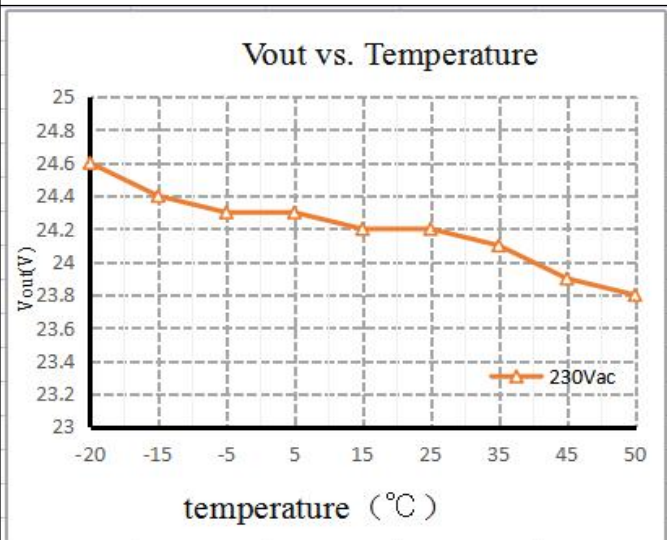
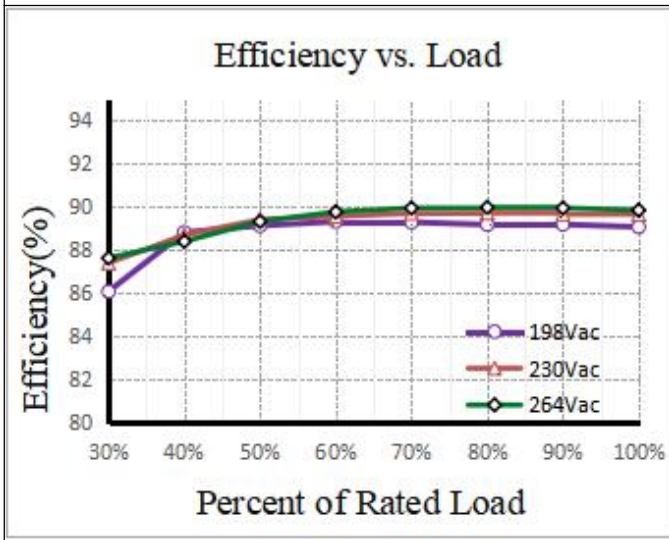

### 5. Dimension and Weight

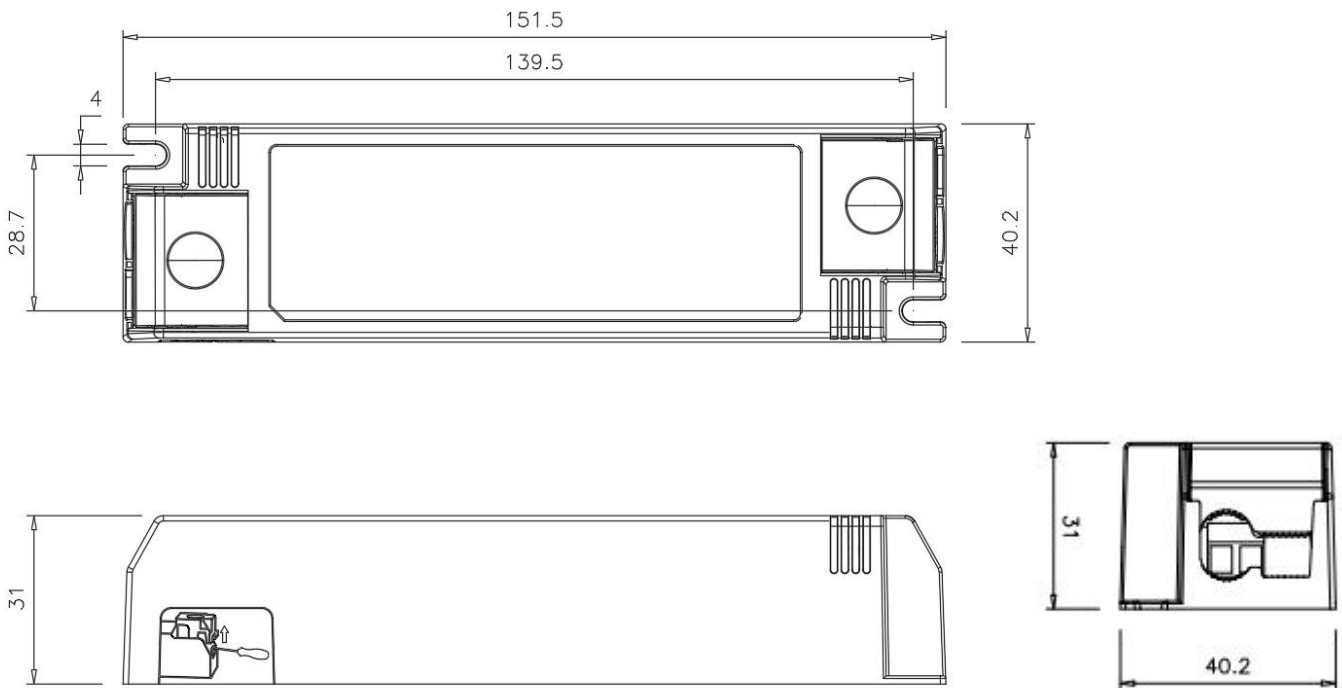

**Remark:**

- Case color is RAL9016 , color difference is controlled at  $\Delta E1.0$ ;
- The unmarked tolerance is  $\pm 0.1\text{mm}$ .

### 6. Wiring Diagram

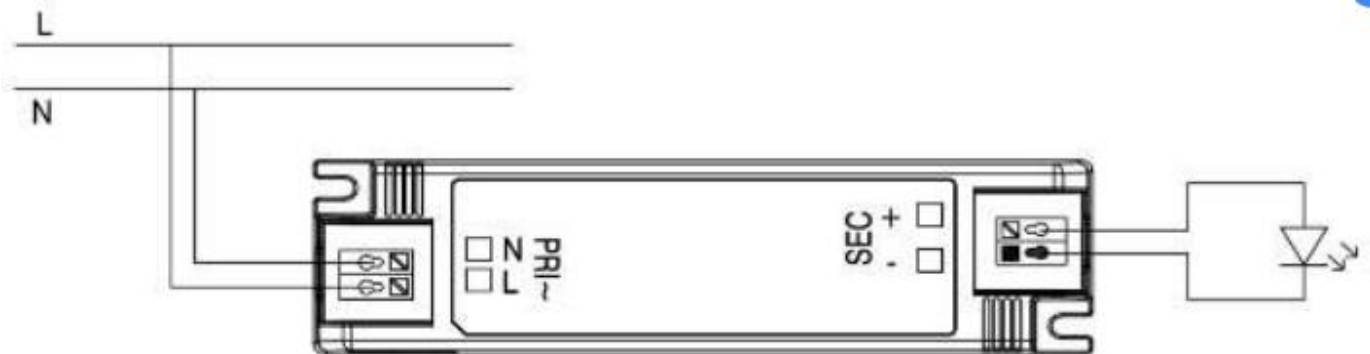

## 7. Packing information

Packing way	Model	Carton L*W*H(mm)	Pcs/Carton	Net weight/ Pcs(kg)	Net weight/ Carton(kg)	Gross weight / Carton(kg)
With white box and manual	CV60W24CG-4	310*200*175	40	0.194	7.76	8.13

## 8. Wiring instructions

- All connections must be kept as short as possible to ensure good EMI behaviour
- Mains leads should be kept apart from LED Driver and other leads (ideally 5 – 10 cm distance)
- Advice the maximum length of output wires is 3 m
- Secondary switching is not permitted (Except for constant voltage)
- Incorrect wiring can damage LED modules.
- The wiring must be protected against short circuits to earth (sharp edged metals parts, metal cable clips, louver, etc.)
- Hot plug-in is not supported due to residual output voltage of > 0 V up to mains voltage. Danger to life.
- When connecting an LED load, restart the device to activate the LED output.
- This can be done via mains reset or via interface (DALI, DSI, switch DIM).

## 9. Replace LED module

- Mains off
- Remove LED module
- Wait for 30 seconds
- Connect LED module again
- Hot plug-in or secondary switching of LEDs is not permitted and may cause a very high current to the LEDs

## 10. REVISION HISTORY

DATE	REV	REMARK
2025-09-27	V1.0	Initial release.