



Constant Voltage Driver

Model : CV30W24CG-1



Model	Input Current	Input Power	Output Power Range	PF	Efficiency	Output Voltage	Output Current	No load Voltage
CV30W24CG-1	≤0.18A	≤36W	1.5-30W	≥0.95	86%	24V	0.0625-1.25A	23~25V

***Test result @230 V, 50 Hz, Full Load**

1. Parameters

Category	Item	Technical Norm
Features	Output Type	Constant Voltage
	IP Grade	IP20
	Insulation Class	Class II
Input	Rated Input Voltage	220-240VAC
	Range of Input Voltage	198-264VAC or 200-280VDC
	Frequency	50/60Hz
	Input Current	≤0.18A
	Input Power	≤ 36W
	Power Factor	≥0.95@230V,50HZ,Full Load
	THD	≤ 11%@230V,50HZ,Full Load
	No-load Power Consumption	≤0.5W
Output	Voltage Accuracy	±5%
	Max. Output Power	30W
	Started Delay Time	≤0.5S (230VAC, full load)
	Voltage Ripple	±2% (< 120 Hz)
	PstLM	≤1
	SVM	≤0.4
Protection	Short Circuit Protection	Auto Recovery
	Overload Protection	Auto Recovery
	No-load Protection	Auto Recovery
	Insulation voltage	I/P to O/P , 3KVac/1min,I/P to PE 1.5Kac/1min
	Insulation resistance	>100M ohm @ 500VDC
	Leakage current	I/P to O/P < 250 μ A
Environment	Ta/Operation Temperature	-20...+50°C
	Ts/Storage Temperature	-40...+85°C
	Tc/Enclosure Temperature	90°C
	Humidity	10% 90%RH
	Atmosphere	86-108KPa

Construction	Connection Method	Push-in Terminal
	Installation	Independent
	PRI Wire preparation	0.75-1.5□
	SEC Wire preparation	0.5-1.5□
	Dimension	135X36X25mm (L*W*H)
Standards	Certification	CE
	Safety Standards	EN61347-2-13:2014/A1:2017 EN62493:2015,EN613471:2015/A1:2021, AS61347.2.13:2018, AS/NZS61347.1:2016 Inc A1
	EMC Standards	EN IEC 55015:2019 EN IEC 55015:2019/A11:2020 EN IEC 61000-3-2:2019 EN 61000-3-3:2013/A1:2019 EN61547:2009
	Performance	EN62384
	Surge	L-N/2KV L N-PE/2KV
Others	RoHS	complied to 2011/65/EU
	Life Time	50000h Ta /Tc
	Warranty	5years , F.R. < 10000ppm
	Noise	≤ 24dB @Background noise ≤ 18dB , Interval ≥ 15cm
<p>Remark</p> <p>All Parameters, if not specified, are measured at 230VAC/50Hz and 25°C ambient temperature.</p> <p>LED Driver is a component of the luminaires ,Luminaires and wire layout will affect the EMC, please check the EMC with end products again.</p>		

2. Connected quantities of different current Breaker

TYPE	Connected quantities of different current Breaker						Input Voltage	Inrush Current	Time
	current (A)	10	13	16	20	25			
	Installation wire diameter	1.5mm ²	2.5mm ²	2.5mm ²	4mm ²	4mm ²			
TYPE B		20	26	32	40	50	@230VAC	30	300uS
TYPE C		32	42	51	64	80			
TYPE D		51	67	82	102	128			

3. Label



4. Dimming curve

NA

5. Lifetime curve

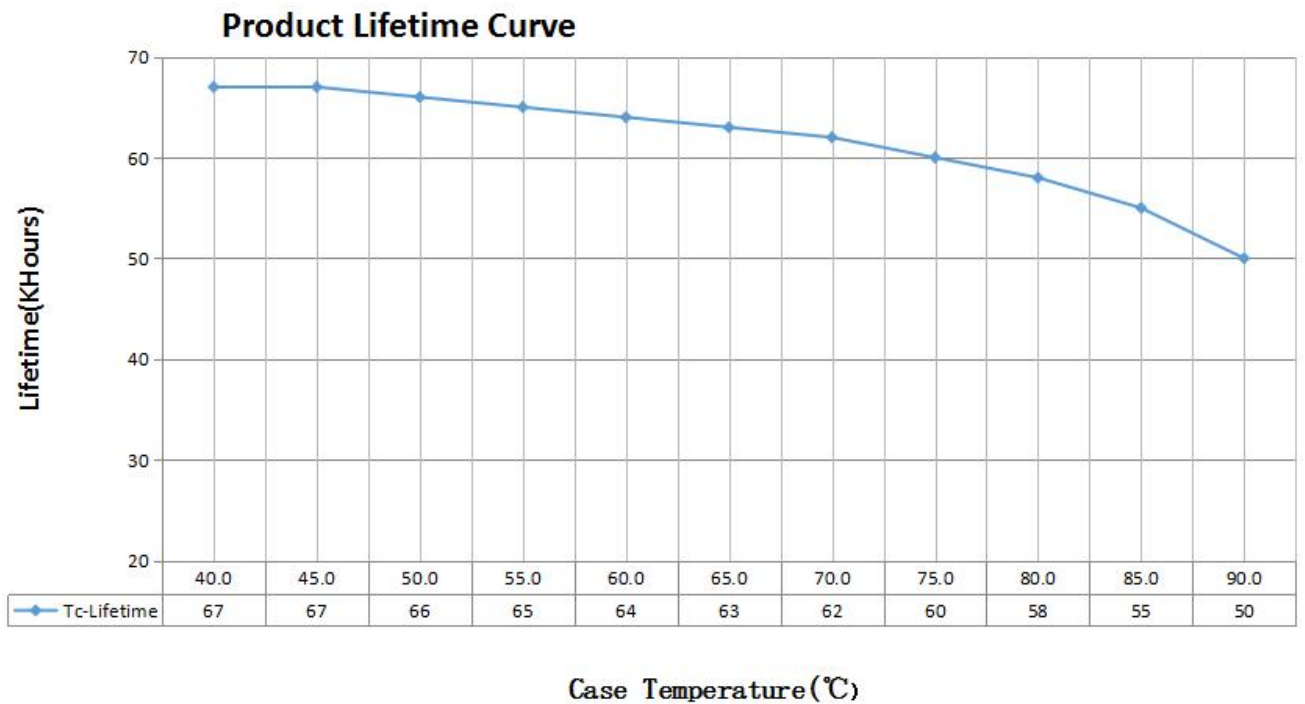

6. Dimension (Unit: mm)

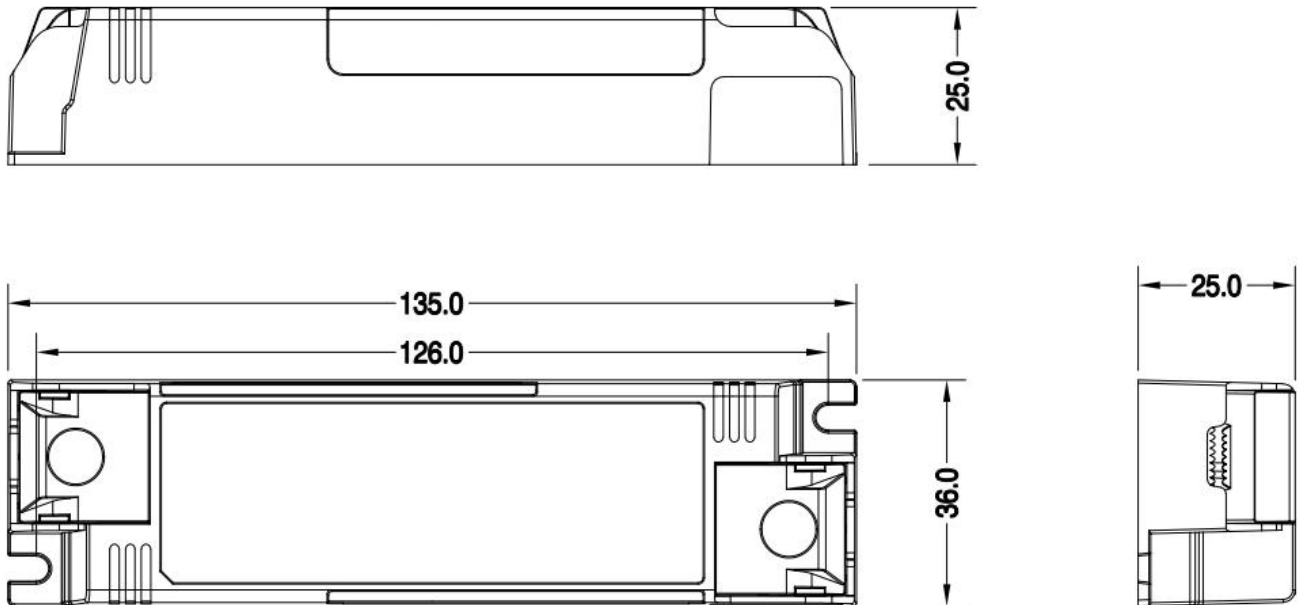

7. Wiring Diagram

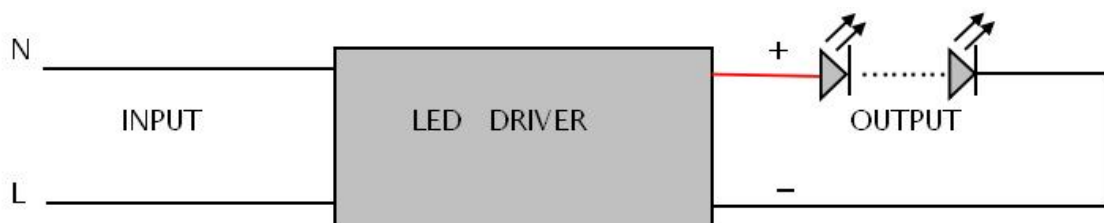

8. Packing information

packing way	Carton L*W*H(mm)	Pcs/Carton	Net weight/ Pcs(kg)	Net weight/ Carton(kg)	Gross weight / Carton(kg)
447*240*200	447*240*200	80	0.0895	7.16	7.72

9. Wiring instructions

- All connections must be kept as short as possible to ensure good EMI behaviour
- Mains leads should be kept apart from LED Driver and other leads (ideally 5 – 10 cm distance)
- Advice the maximum length of output wires is 3 m
- Secondary switching is not permitted (Except for constant voltage)
- Incorrect wiring can damage LED modules.
- The wiring must be protected against short circuits to earth (sharp edged metals parts, metal cable clips, louver, etc.)

10. REVISION HISTORY

DATE	VER	REMARK
2023-02-01	V1.0	Initial release.