



APPROVAL SHEET

BRAND	The logo for WinPow A+, featuring the word "WINPOW" in yellow with a black outline, "A+" in yellow, and a black globe icon behind the text.
PRODUCT	3.0V LITHIUM-MANGANESE BUTTON CELL
MODEL	CR2032
PREPARED BY	
APPROVED BY	
DATE	AUG. 8, 2015



1. 【SCOPE】

This specification applies to the following 3.0v lithium button cell CR2032

2. 【RATINGS】

TABLE I :

ITEM		UNIT	SPECIFICATIONS	CONDITIONS
Nominal voltage		V	3.0	
Nominal capacity		mAh	210	Standard discharge with load 15kΩ
Instantaneous short-circuit current		mA	≥250	Time≤0.5 second
Off-load voltage		V	≥3.2	
Operating temperature		℃	-20~60	
Standard weight		g	3.0	Unit cell
Service output	Initial	Standard	1100 h	Continuous discharge with load 15kΩ, till 2.0v end-voltage
	After 12 months storage	Standard	1000 h	

TABLE II :

ITEM	CONDITIONS	CHARACTERISTICS	
Thermal durability	Kept for 20 days at 60℃±3℃, then continuously discharge with 15kΩ load till 2.0v end-voltage	Standard	1100 h
Self-discharge rate	Stored for 12 months at normal temperature and humidity	≤5%	

3. 【PERFORMANCE AND TEST METHODS】

Unless otherwise stated, all the testing is carried out under the condition: environmental temperature, 20℃~25℃; environmental humidity, 65±20%. Please refer to Table III

4. 【SUGGESTIONS AND CAUTIONS】

- 4.1 Install batteries correctly.
- 4.2 Ensure the contact points to be clean and conductive.
- 4.3 Do not mix different types, different brands batteries to serve together.
- 4.4 Do not heat, recharge the batteries.
- 4.5 Do not dispose of the batteries in fire.
- 4.6 Keep away from the small children, if swallowed promptly see doctor.
- 4.7 Pay attention to the producing date.

TABLE III:

No	ITEM	TEST METHODS	STANDARD	
			Diameter	Height
1	Dimensions	Using vernier caliper (accuracy ≥ 0.02) while avoiding short-circuit	Diameter	20.0 (-0.2) mm
			Height	3.2 (-0.2) mm
2	Off-load voltage	Using multimeter (accuracy $\geq 0.25\%$) internal resistance $\geq 1M\Omega$	≥ 3.2 v	
3	Instantaneous short-circuit current	Time of short-circuit should be less than 0.5 second and avoid repeated test within half an hour	≥ 250 mA	
4	Appearance	Eyeballing	Bright, clean, no rust, no leakage, And no flaw	
5	Capacity	Continuously discharge for 8 hours with load $15k\Omega$, temperature at $20\sim 25^{\circ}C$, humidity at $65\pm 20\%$ till 2.0v end-voltage (for fresh battery only: within 3 months)	≥ 1100 h	
6	Vibration test	Put battery on the platform of the vibrations machine, start the machine and adjust the frequency form 10 times per minute to 15 times per minute. keep it running for an hour	Characteristics keep stability	
7	Leakage at high temperature test	Stored under temperature ($60^{\circ}C$) for 7 days	No leakage allowed	
8	Over discharge Test	After 2.0v end-voltage, continuously discharged for 5 hours	No leakage allowed	

5. 【CUTAWAY DIAGRAM OF 3.0V LITHIUM MANGANESE DIOXIDE BUTTON CELL】

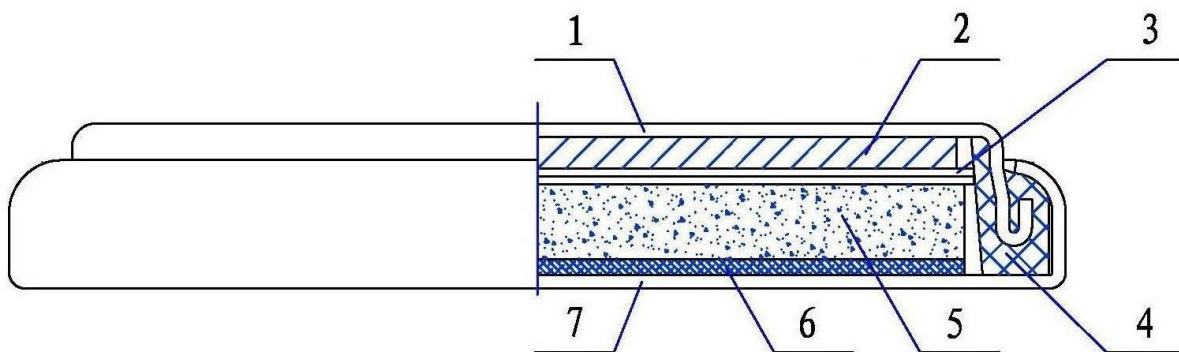

- 1、Cathode Shell 2、Cathode (slice of lithium) 3、Septum 4、Gasket
 5、Anode (MnO_2) 6、Anode collector net 7、Anode shell



6. 【DISCHARGE CHARACTERISTICS】

标准曲线 STANDARD CHARACTERISTICS

定电阻放电曲线
Discharge Characteristics

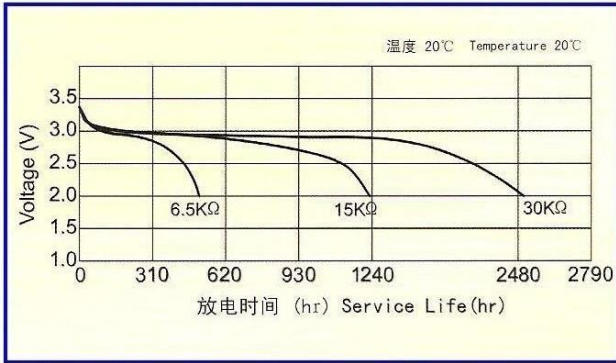

温度放电曲线
Temperature Characteristics

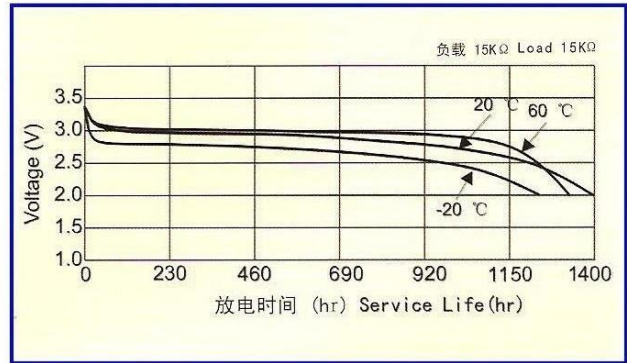

电阻容量曲线
Load-capacity

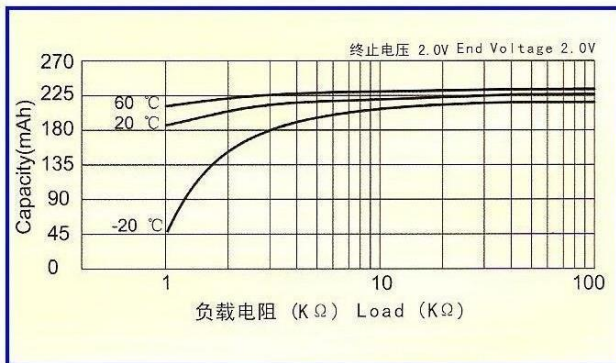

脉冲放电曲线
Pulse Discharge Characteristics

