



ISO9001 & ISO14001 & TS16949 **CHILISIN ELECTRONICS CORP.**

Lead-Free & RoHs Compliance!!

SPECIFICATION FOR APPROVAL

CUSTOMER : _____

CUSTOMER P/N : _____

OUR DWG No : _____

QUANTITY : 0 Pcs. **DATE :** 2013/03/07

ITEM : CMM31T-SERIES

SPECIFICATION ACCEPTED BY:	
COMPONENT ENGINEER	
ELECTRICAL ENGINEER	
MECHANICAL ENGINEER	
APPROVED	
REJECTED	

<p>奇力新電子股份有限公司 CHILISIN ELECTRONICS CORP. NO.29,LANE 301,TEHHSIN ROAD,HUKOU, HSINCHU,TAIWAN,303, REPUBLIC OF CHINA TEL : (03) 599-2646 FAX : (03) 599-9176 E-mail : Sales@chilisin.com.tw http : //www.chilisin.com.tw</p> <p>台北營業處 Taipei Office 1F., No.2, Aly. 1, Ln. 235, Baoqiao Rd., Xindian Dist., New Taipei City 231, Taiwan TEL : +886-2-6629-5588~9 FAX : +886-2-6629-0088 E-mail : Sales@chilisin.com.tw</p>	<p>東莞奇力新電子有限公司 Chilisin Electronics (Dongguan) Co., Ltd. No. 78, Puxing Rd., Yuliangwei Administration Area, Qingxi Town, Dongguan City, Guangdong,China TEL : +86-769-8773-0251~3 FAX : +86-769-8773-0232 E-mail : cect@chilisin.com.tw</p> <p>奇力新電子(蘇州)有限公司 Chilisin Electronics (Suzhou) Co., Ltd. No.143,Song Shan Rd., Suzhou New District, Suzhou,China Postal Code:215129 TEL:+86-512-6841-2350 FAX:+86-512-6841-2356 E-mail : suzhou@chilisin.com.tw</p>
---	---

DRAWN BY 陳瑞揚 ryan.chen	CHECKED BY 張麗玲 ll.chang	APPROVED BY 陳瑞揚 ryan.chen
----------------------------------	-----------------------------------	-------------------------------------

CMM31T Series Specification

1 Scope: This specification applies to CMM FILTER

2 Part Numbering: Product Identification

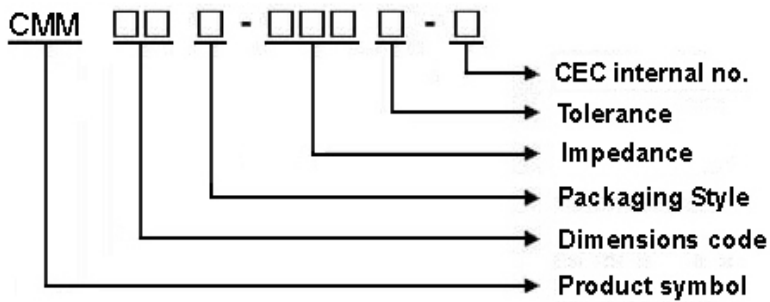

3 Rating:

Operating Temperature: $-40^{\circ}\text{C} \sim 105^{\circ}\text{C}$ (Including self - temperature rise)

Storage Temperature: $20^{\circ}\text{C} \sim 25^{\circ}\text{C}$ R.H. 65% (For Reference)

4 Marking:

No Marking

5 Standard Testing Condition

	Unless otherwise specified	In case of doubt
Temperature	Ordinary Temperature(15 to 35°C)	20±2°C
Humidity	Ordinary Humidity(25 to 85% RH)	60 to 70 % RH

CMM31T Series Specification

6 Configuration and Dimensions:

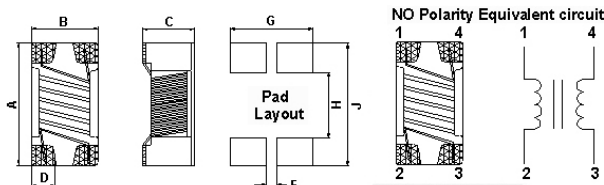

TYPE	A m/m	B m/m	C m/m	D m/m	E m/m	F m/m	G m/m	H m/m	I m/m
CMM31	3.2±0.2	1.6±0.2	1.9±0.2	0.6	0.6	0.4	1.6	1.6	3.7

7 ELECTRICAL CHARACTERISTICS :

Part No.	Z (Ω)	RDC (Ω)Max.	IDC (mA)	Rated Voltage (Vdc)	Insulation Resistance (MΩ)(min)	Tolerance (±%)	Test Freq. (MHz)
CMM31T-90□-N	90	0.3	370	50	10	20	100
CMM31T-121□-N	120	0.3	370	50	10	20	100
CMM31T-161□-N	160	0.4	340	50	10	20	100
CMM31T-221□-N	220	0.4	320	50	10	20	100
CMM31T-261□-N	260	0.5	310	50	10	20	100
CMM31T-601□-N	600	0.8	260	50	10	20	100
CMM31T-102□-N	1000	1	230	50	10	20	100
CMM31T-222□-N	2200	1.2	200	50	10	20	100

NOTE: □-tolerance M=±20%

1. Operating temperature range - 40 °C ~ 105 °C (Including self - temperature rise)

2. RDC: SINGLE WIRE TEST VALUE

3. IDC for Inductance drop 10% from its value without current.

"-N" FOR COMPLETELY LEAD FREE TYPE (INCLUDING FERRITE BODY & SOLDER)

CMM31T Series Specification

8 CMM31T Series

8.1 Construction:

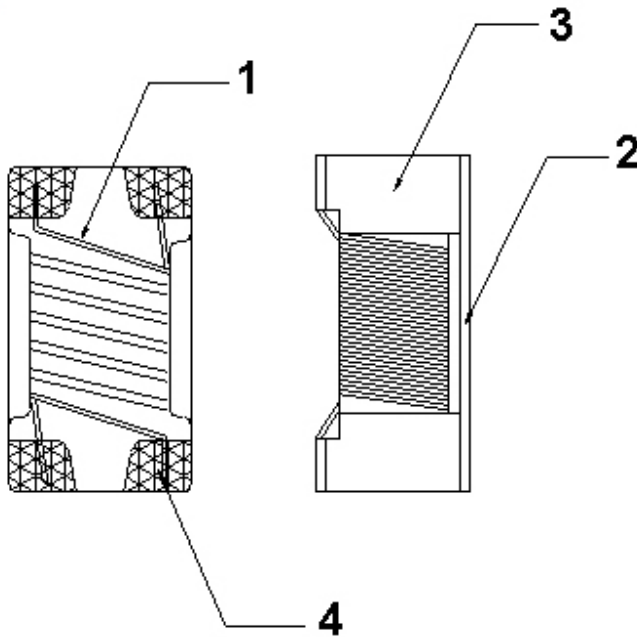

8.2 Material List:

ITEM	PART	DESCRIPTION	SUPPLIES
1	WIRE	Grade 180	ELEKTRISOLA
2	Cover sheet	FERRITE	CHILISIN
3	CORE	FERRITE	CHILISIN
4	TERMINAL	Ag/Ni/Sn	



CMM31T Series Specification

9 Common Mode Choke / RELIABILITY TEST

1-1.Environmental Performance

No	Item	Specification	Test Method															
1-1-1	Temperature Cycle	Appearance: No Damage Impedance: within±20% of initial value	One cycle: <table border="1" style="width: 100%; border-collapse: collapse;"> <thead> <tr> <th>Step</th> <th>Temperature (°C)</th> <th>Time (min)</th> </tr> </thead> <tbody> <tr> <td>1</td> <td>-40±3</td> <td>30</td> </tr> <tr> <td>2</td> <td>25±2</td> <td>3</td> </tr> <tr> <td>3</td> <td>105±3</td> <td>30</td> </tr> <tr> <td>4</td> <td>25±2</td> <td>3</td> </tr> </tbody> </table> Total: 5 cycles Measured After Exposure in The Room Condition For 1hrs	Step	Temperature (°C)	Time (min)	1	-40±3	30	2	25±2	3	3	105±3	30	4	25±2	3
Step	Temperature (°C)	Time (min)																
1	-40±3	30																
2	25±2	3																
3	105±3	30																
4	25±2	3																
1-1-2	Humidity Resistance		Temperature: 40±2°C Relative Humidity: 90 ~ 95% Time: 100hrs Measured After Exposure In The Room Condition For 1hrs															
1-1-3	High Temperature Resistance		Temperature: 85±3°C Time: 50Hrs Measured After Exposure In The Room Condition For 1Hrs															
1-1-4	Low Temperature Resistance		Temperature: -40±3°C Time: 50Hrs Measured After Exposure In The Room Condition For 1Hrs															
1-1-5	High Temperature Load Life	There should be no evidence of short or open circle	Temperature: 85±3°C Load: Allowed DC Current Time: 500Hrs															
1-1-6	Humidity Load Life		Temperature: 40±2°C Relative Humidity: 90~95% Load: Allowed DC Current Time: 500Hrs															

1-2.Mechanical Performance

No	Item	Specification	Test Method
1-2-1	Resistance To Soldering Heat	Appearance: No Damage	1. The device should be reflow soldered on PCB (peak 260°C±5°C for 10 seconds) 2. Solder Composition: Sn/Ag3.0/Cu0.5 3. Test time: 6 minutes
1-2-2	Solder ability	The electrodes shall be at least 95% covered with new solder coating	1. Pre-Heating: 150°C, 1min. 2. Solder Composition: Sn/Ag3.0/Cu0.5 3. Solder Temperature: 245±5°C. 4. Immersion Time: 4±1 sec.
1-2-3	Componment Adhesion (Push Test)	1 Lbs. For CMM11 2 Lbs. For other	The device should be reflow soldered (245±5°C For 10 seconds) to a tinned copper substrate. A force gauge should be applied to the side of the component. The device must withstand a minimum force of 2 pounds without a failure of the termination attached to component

CMM31T Series Specification

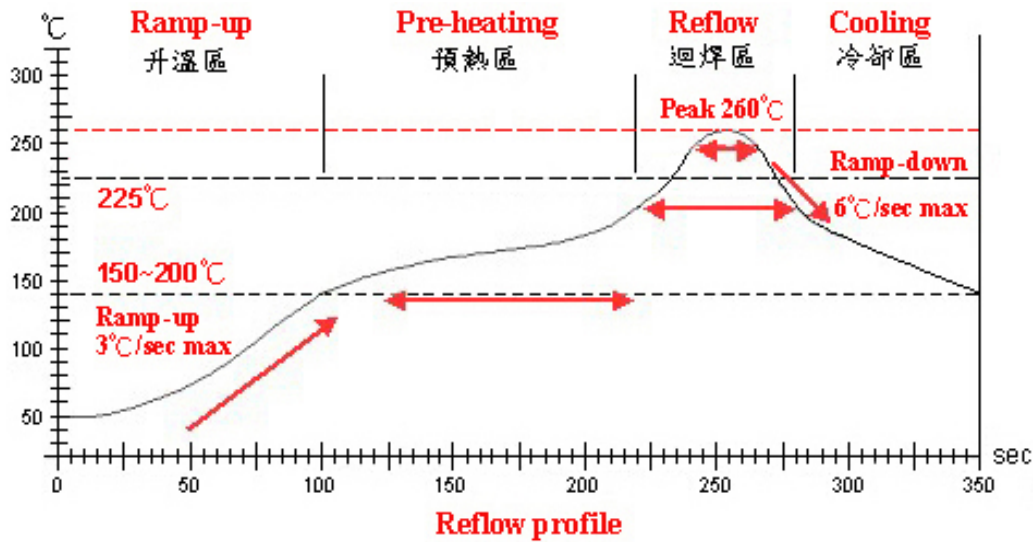
Lead-Free(LF) 標準溫度分析範圍

Refer to J-STD-020C

管制項目 Item.	升温區 Ramp-up	預熱區 Pre-heating	迴焊區 Reflow	Peak Temp	冷卻區 Cooling
溫度範圍 Temp.scope	R.T. ~ 150°C	150°C ~ 200°C	225°C	260±5°C	Peak Temp. ~ 150°C
實際時間 Time result	—	60 ~ 180 sec	20 ~ 60 sec	5 ~ 10 sec	—

NOTE :

1. Re-flow possible times : within 2 times
2. Nitrogen adopted is recommended while in re-flow

CMM31T Series Specification

11 PACKAGING

11.1 Packaging -Cover tape

The force for tearing off cover tape is 10 to 100 grams in the arrow direction.

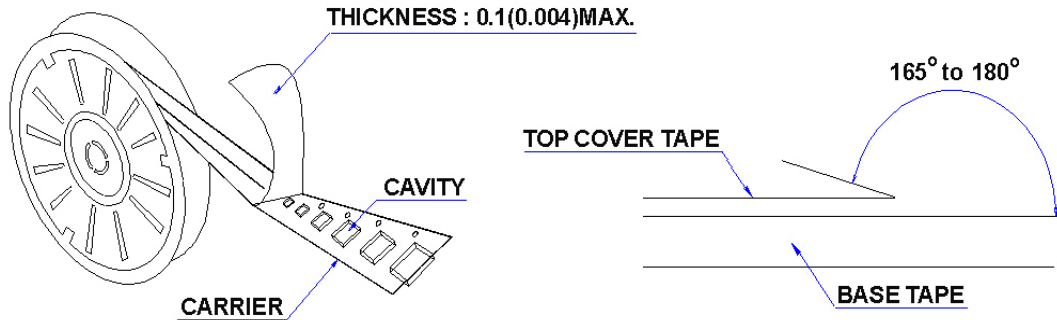

11.2 Packaging Quantity

TYPE	BULK	PCS/REEL
CMM21	✓	2000
CMM31	✓	2000

11.3 Reel Dimensions

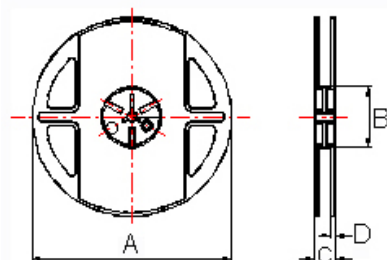

Reel Dimensions : m/m

TYPE	A	B	C	D
CMM21	178	60	12	1.5
CMM31	178	60	12	1.5

CMM31T Series Specification

11 PACKAGING

11.4 Tape Dimensions in mm

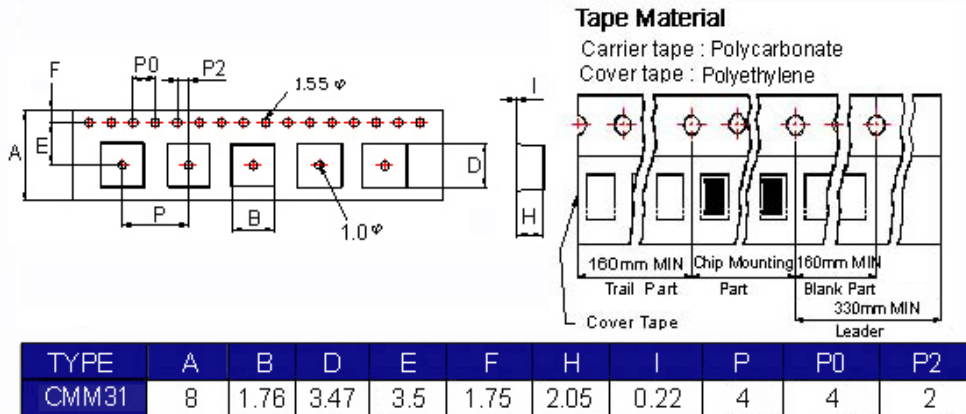

12 Recommended Pattern



13 Note:

1. Please make sure that your product is has been evaluated and confirmed against your specifications when our product is mounted to your product.
2. Do not knock nor drop.
3. All the items and parameters in this product specification have been prescribed on the premise that our product is used for the purpose, under the condition and in the environment agreed upon between you and us. You are requested not to use our product deviating from such agreement.
4. Please keep the distance between transformer/coil and other components (refer to the standard IEC 950)