

Constant Current Driver

Model : CC6WXXXA23



Model	Output Current	Input Current	Input Power	Output Power Range	PF	Efficiency	Output Voltage	No load Voltage
CC6W150A23	150mA	≤0.09A	≤11W	3.75-6.00W	≥0.8	≥80%	25-40V	≤55V
CC6W180A23	180mA	≤0.09A	≤11W	3.60-6.84W	≥0.8	≥80%	20-38V	≤55V
CC6W200A23	200mA	≤0.09A	≤11W	4.00-7.20W	≥0.8	≥78%	20-36V	≤50V
CC6W250A23	250mA	≤0.09A	≤11W	4.00-6.00W	≥0.8	≥78%	16-24V	≤35V
CC6W300A23	300mA	≤0.09A	≤11W	3.60-6.30W	≥0.8	≥78%	12-21V	≤33V
CC6W350A23	350mA	≤0.09A	≤11W	4.20-7W	≥0.8	≥78%	12-20V	≤33V
CC6W500A23	500mA	≤0.09A	≤11W	3.00-6.50W	≥0.8	≥78%	6-13V	≤25V
CC6W550A23	550mA	≤0.09A	≤11W	3.30-7.15W	≥0.8	≥78%	6-13V	≤25V
CC6W700A23	700mA	≤0.09A	≤11W	3.50-6.30W	≥0.8	≥78%	5-9V	≤16V

* Test result @230V, 50Hz, Full Load.

1. Parameters

Category	Item	Technical Norm
Features	Output Type	Constant Current
	IP Grade	IP20
	Insulation Class	Class II
Input	Rated Input Voltage	220-240VAC
	Range of Input Voltage	180-264VAC or 230-280VDC
	Frequency	50/60Hz
	Input Current	≤0.09A
	Input Power	≤ 11W (230VAC, full load)
	Power Factor	≥0.8(230VAC, full load)
	THD	≤70%
	No-load Power Consumption	≤0.5W @230VAC
	Inrush Current	≤15A/200us (230VAC, Full-load)
Output	Current Accuracy	±5%
	Max. Output Power	7.2W
	Started Delay Time	≤0.5S (230VAC, full load)
	Current Ripple	±7% (Imax-Imin) / (Imax+Imin)
	PstLM	≤1

	SVM	≤0.4
Protection	Short Circuit Protection	Auto Recovery
	Overload Protection	Auto Recovery
	No-load Protection	Auto Recovery
Protection	Insulation voltage	I/P to O/P , 3KVac/1min
	Insulation resistance	>100M ohm @ 500VDC
	Leakage current	I/P to O/P < 250μA
Environment	Ta/Operation Temperature	-25....+50°C
	Ts/Storage Temperature	-30....+85°C
	Tc/Enclosure Temperature	85°C
	Humidity	10%.... 90%RH
	Atmosphere	86-108KPa
Construction	Connection Method	Direct Lead
	Installation	Build-in
	PRI Wire preparation	0.5-0.75 [□]
	SEC Wire preparation	0.3-0.75 [□]
	Dimension	55X27X21mm (L*W*H)
Standards	Certification	CE/TUV/SAA
	Safety Standards	EN61347-2-13:2014/A1:2017 EN62384:2006/A1:2009 EN 61347-1:2015/A1:2021,AS61347.2.13:2018, AS/NZS61347.1:2016 Inc A1
	EMC Standards	EN IEC 55015:2019,EN IEC 55015:2019/A11:2019, EN IEC 61000-3-2:2019,EN 61000-3-3:2013/A1:2019, EN61547:2009 ,EN IEC 55015:2019/A11:2020
	Performance	EN62384
	Surge	L-N/1KV
Others	RoHS	complied to 2011/65/EU
	Life Time	50,000h @ Ta/ Tc
	Warranty	5years , F.R. < 10000ppm

Remark

1. All Parameters, if not specified, are measured at 230VAC/50Hz and 25°C ambient temperature.
2. LED Driver is a component of the luminaires ,Luminaires and wire layout will affect the EMC, please check the EMC with end products again.

2. Connected quantities of different current Breaker

TYPE	Connected quantities of different current Breaker						Input Voltage	Inrush Current	Time
	current (A)	10	13	16	20	25			
	Installation wire diameter	1.5mm ²	2.5mm ²	2.5mm ²	4mm ²	4mm ²			
TYPE B	40	52	64	80	100	@230VAC	15	200us	
TYPE C	64	83	102	128	160				
TYPE D	102	133	164	205	256				

3. Label (For example)



4. Lifetime curve

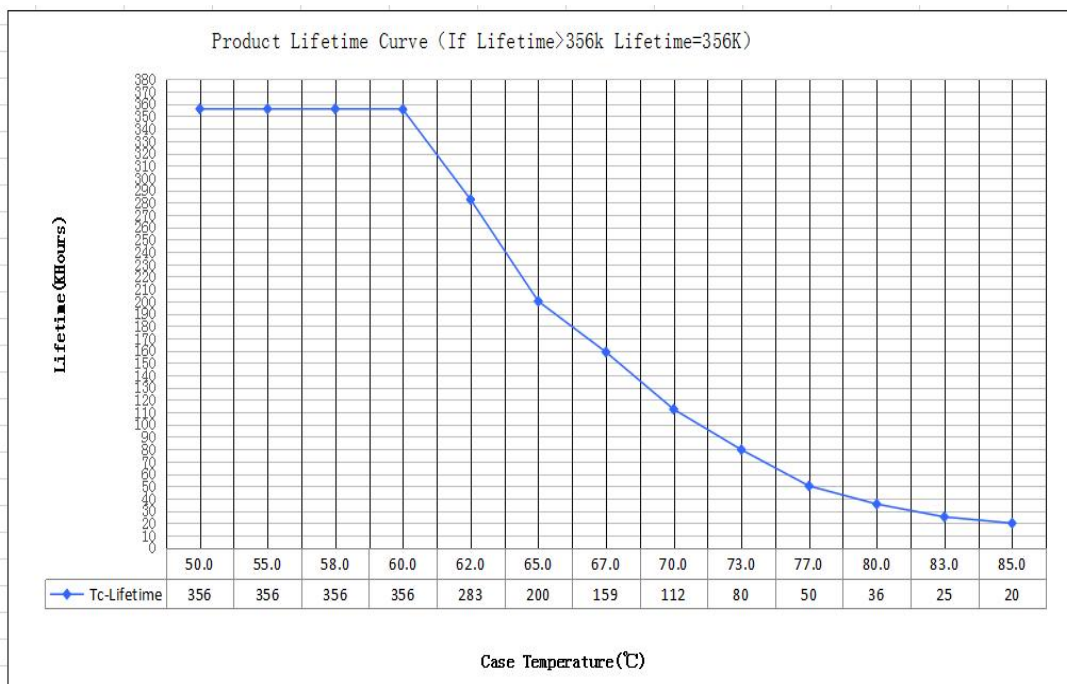

5. Dimension (Unit: mm)

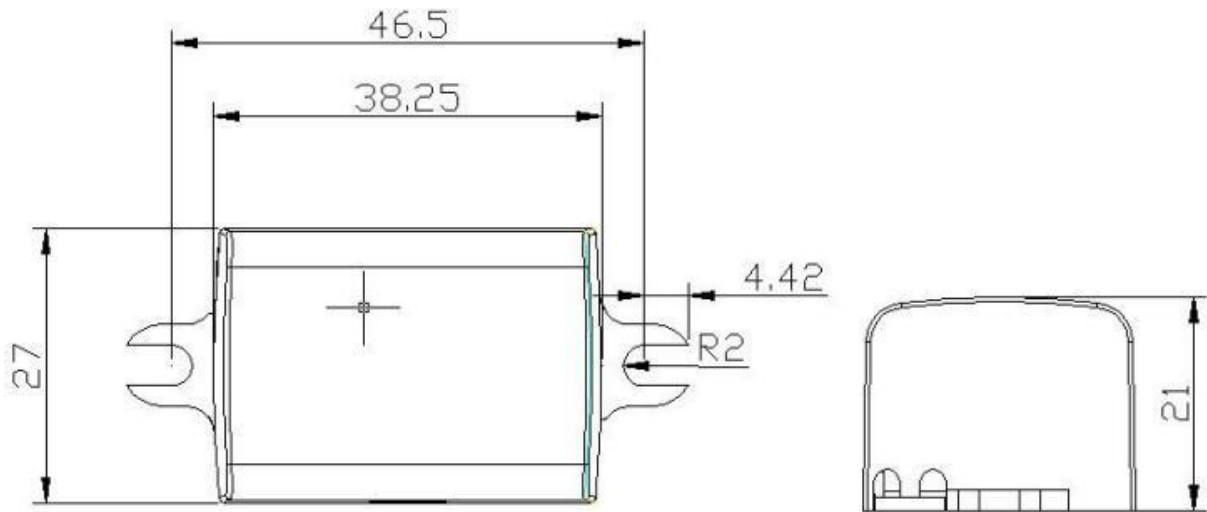

6. Packing information

Packing way	Model	Carton L*W*H(mm)	Pcs/ Carton	Net weight/ Pcs(kg)	Net weight/ Carton(kg)	Gross weight/ Carton(kg)
With white box and manual	CC6WXXXA23	457*250*220	205	0.036	7.38	8.45
Without white box and manual		420*280*180	240	0.036	8.64	9.54

7. Wiring Diagram

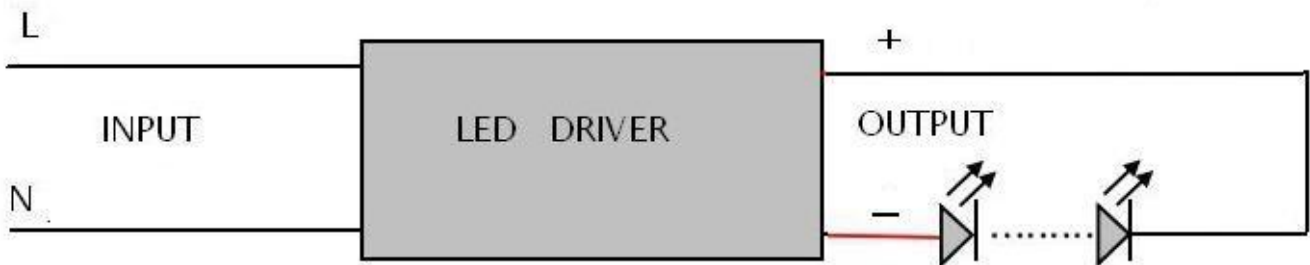

8. Wiring instructions

- All connections must be kept as short as possible to ensure good EMI behaviour
- Mains leads should be kept apart from LED Driver and other leads (ideally 5 – 10 cm distance)
- Advice the maximum length of output wires is 3 m
- Secondary switching is not permitted (Except for constant voltage)
- Incorrect wiring can damage LED modules.
- The wiring must be protected against short circuits to earth (sharp edged metals parts, metal cable clips, louver, etc.)

9. REVISION HISTORY

DATE	VER	REMARK
2022-10-13	V1.0	Initial release.