



Constant Current Driver

Model : CC4WXXXA29



Model	Input Current	Input Power	Output Power Range	PF	Efficiency	Output Current	Output Voltage	No load Voltage
CC4W200A29	0.09A	4.9W	2.6-3.5W	0.45	73%	200mA	13-17.5V	29V
CC4W350A29	0.09A	4.9W	1-3.32W	0.45	71%	350mA	2.7-9.5V	21V
CC4W500A29	0.09A	4.9W	1.4-3.25W	0.45	70%	500mA	2.7-6.5V	18V
CC4W700A29	0.09A	4.9W	1.9-3.15W	0.45	68%	700mA	2.7-4.5V	17V

***Test result @230 V, 50 Hz, Full Load**

1. Parameters

category	Item	Technical Norm
Features	Output Type	Constant Current
	IP Grade	IP20
	Insulation Class	Class II
Input	Rated Input Voltage	100-240VAC
	Range of Input Voltage	90-264VAC or 180-280VDC
	Frequency	50/60Hz
	Input Current	≤0.15A
	Input Power	≤ 4.9W
	Power Factor	N/A
	THD	N/A
	No-load Power Consumption	≤0.5W
	Inrush Current	≤10A/300us
	Connected quantity of 10A Breaker	22pcs/type A ; 36pcs/type B; 60pcs/type C
	Connected quantity of 16A Breaker	35pcs/type A ; 58pcs/type B; 96pcs/type C
Connected quantity of 20A Breaker	44pcs/type A ; 72pcs/type B; 120pcs/type C	
Output	Current Accuracy	±7%(4W200 & 4W350)
	Current Accuracy	±5%(4W500 & 4W700)
	Max. Output Power	3.32W
	Started Delay Time	≤0.5S (230VAC, full load)
	Current Ripple	±5% (Imax-Imin) / (Imax+Imin)
Protection	Short Circuit Protection	Auto Recovery
	Overload Protection	Auto Recovery
	No-load Protection	Auto Recovery
	Insulation voltage	I/P to O/P , 3KVac/1min,I/P to PE 1.5Kac/1min

	Insulation resistance	>100M ohm @ 500VDC
	Leakage current	I/P to O/P < 250µA
Environment	Ta/Operation Temperature	-25....+50 °C
	Ts/Storage Temperature	-40....+85 °C
	Tc/Enclosure Temperature	85 °C
	Humidity	10%.... 90%RH
	Atmosphere	86-108KPa
Construction	Connection Method	Direct Lead
	Installation	Build-in
	PRI Wire preparation	0.5-0.75 [□]
	SEC Wire preparation	0.5-0.75 [□]
	Dimension	47.5*27*20(L*W*H)
Standards	Certification	TUV/CE/SAA
	Safety Standards	EN61347-1:2015,EN61347-2-13:2014/A1:2017, EN62493:2015, AS/NZS IEC61347.2.13:2013, AS/NZS 61347.1:2016
	EMC Standards	EN55015:2013/A1:2015,EN61000-3-2:2014, EN61000-3-3:2013,EN61547:2009
	Performance	EN62384
	Surge	L-N/1KV L N-PE/2KV
Others	RoHS	complied to 2011/65/EU
	Life Time	50,000h @ Ta/ Tc
	Warranty	5years , F.R. < 10000ppm

Remark

1. All Parameters, if not specified, are measured at 230VAC/50Hz and 25°C ambient temperature.
2. LED Driver is a component of the luminaires ,Luminaires and wire layout will affect the EMC, please check the EMC with end products again.

2. Label (For example)



3. Lifetime curve

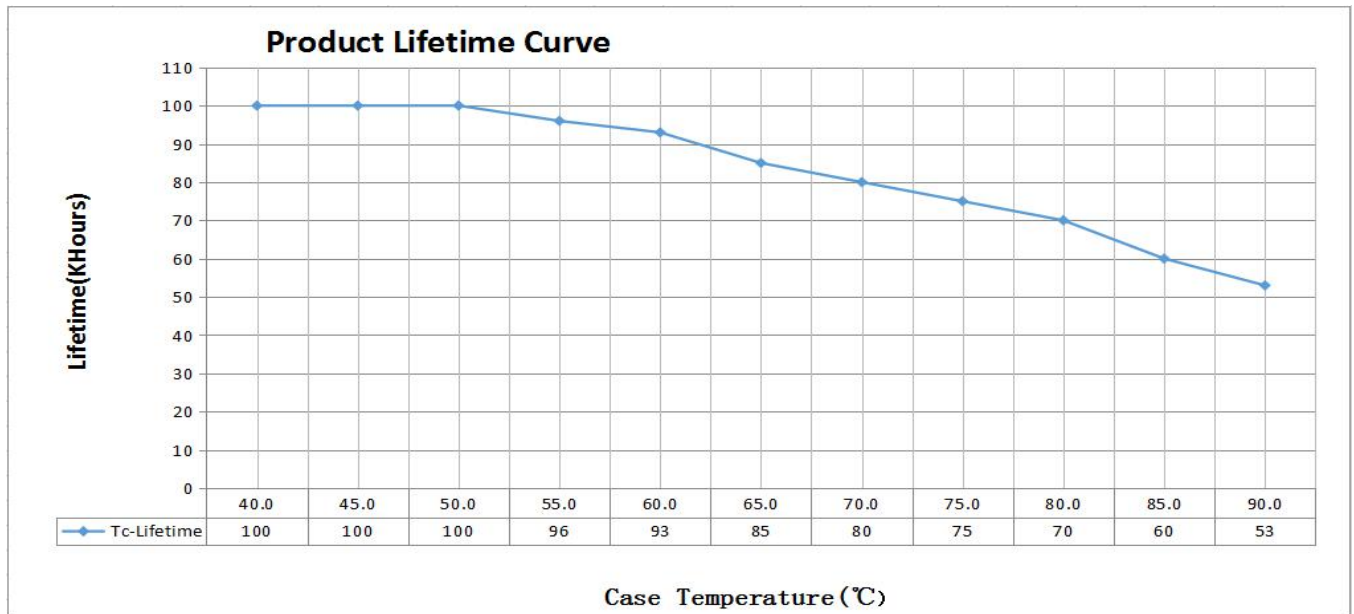

4. Dimension (Unit: mm)

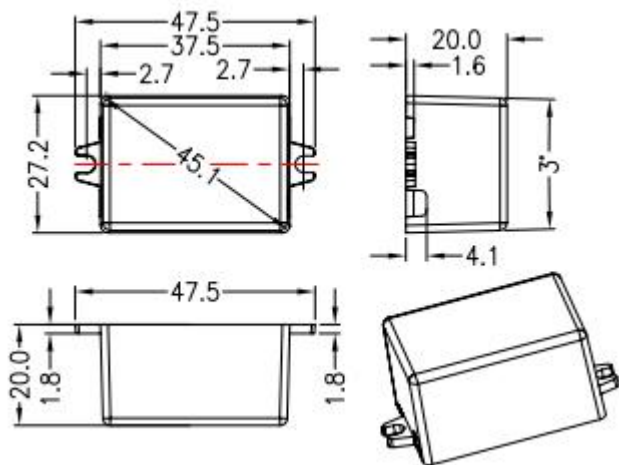

5. Wiring Diagram

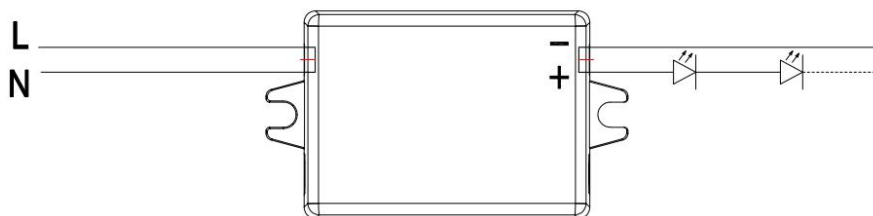

6. Packing information

packing way	Carton L*W*H(mm)	Pcs/Carton	Net weight/ Pcs(kg)	Net weight/ Carton(kg)	Gross weight / Carton(kg)
Industrial	450*240*200	T.B.D	T.B.D	T.B.D	T.B.D

7. Wiring instructions

- All connections must be kept as short as possible to ensure good EMI behaviour
- Mains leads should be kept apart from LED Driver and other leads (ideally 5 – 10 cm distance)
- Advice the maximum length of output wires is 3 m
- Secondary switching is not permitted (Except for constant voltage)
- Incorrect wiring can damage LED modules.
- The wiring must be protected against short circuits to earth (sharp edged metals parts, metal cable clips, louver, etc.)