

Model	Output Current	Input Current	Input Power	Output Power Range	PF	Efficiency (typ.)*	Output Voltage	No load Voltage
CC36W150-900 DALI	150mA	0.10A	9.3W	0.37-7.50W	0.80	80%	2.5-50V	60V Max.
	200mA	0.11A	12.3W	0.50-10.00W	0.81	81%		
	250mA	0.12A	15.2W	0.62-12.50W	0.82	82%		
	300mA	0.13A	18.0W	0.75-15.00W	0.83	83%		
	350mA	0.14A	20.8W	0.87-17.50W	0.84	84%		
	400mA	0.15A	23.5W	1.00-20.00W	0.85	85%		
	450mA	0.16A	26.1W	1.12-22.50W	0.86	86%		
	500mA	0.17A	29.0W	1.25-25.00W	0.87	86%		
	550mA	0.18A	31.6W	1.37-27.50W	0.88	87%		
	600mA	0.19A	34.4W	1.50-30.00W	0.89	87%		
	650mA	0.20A	37.3W	1.62-32.50W	0.90	87%		
	700mA	0.21A	39.7W	1.75-35.00W	0.91	88%		
	750mA	0.22A	35.7W	1.87-31.50W	0.92	88%	2.5-42V	
	800mA	0.23A	38.1W	2.00-33.60W	0.93	88%		
	850mA	0.24A	40.5W	2.12-35.70W	0.94	88%		
	900mA	0.25A	40.9W	2.25-36.00W	0.95	88%	2.5-40V	

1. Parameters

category	Item	Technical Norm
Features	Output Type	Constant Current
	Dimming Type	DALI-2 / Touch Dim
	Output Features	Isolation
	IP Grade	IP20
	Insulation Class	Class II (compatible Class I)
Input	Rated Input Voltage	220-240VAC
	Range of Input Voltage	198-264VAC
	Range of DC Input Voltage	180-280VDC
	Frequency	0/50/60Hz, Range:0/47-63Hz
	Input Current	≤0.25A max
	Input Power	≤40.9W max
	Power Factor	≥0.95 (230VAC, full load)
	THD	≤10% (230VAC, full load)
	Standby Power Consumption	≤0.45W @230VAC (DALI system DIM to off)
	Inrush Current	≤8.5A/16us (230VAC, full load)
	Connected quantity of 10A Breaker	23pcs/type A ; 37pcs/type B ; 59pcs/type C
Connected quantity of 16A Breaker	37pcs/type A; 59pcs/type B ; 94pcs/type C	
Connected quantity of 20A Breaker	46pcs/type A; 74pcs/type B ; 118pcs/type C	
Output	Output Voltage	2.5-50VDC@150-700mA 2.5-42VDC@750-850mA 2.5-40VDC@900mA
	No Load Voltage (Uout)	60VDC Max.
	Output Current	150-900mA (Factory set current of 150mA)
	Max. Output Power	36W
	Efficiency	≥88% (230VAC, full load@max current)
	Output LF current ripple (< 120 Hz)	±3% (Imax-Imin) / (Imax+Imin)
	Current Accuracy	±5%
	Output PstLM (at full load)	≤1
	Output SVM (at full load)	≤0.4
	Starting Time (AC mode)	≤0.8S (230VAC, full load, by DALI system)
	Starting Time (DC mode)	≤0.4S
Switching over time (AC/DC)	≤0.4S	
Control Method	PUSH dimming	PUSH dimming (Max. lead wire length: 20m,same port of DALI)
	DALI function	DALI dimming (Max. lead wire length: 30m) logarithm or linear dimming curve selectable
	Dimming range	DALI dimming: 1%-100%
Protection	Short Circuit Protection	Auto Recovery
	Overload Protection	Auto Recovery (not be hot swap)
	No-load Protection	Auto Recovery

	Insulation voltage	3000V 5mA 60S between P-S, 1500V 5mA 60S between P-E
	Insulation resistance	>100M ohm @ 500VDC L/N to PE
	Leakage current	< 700µA, I/P to O/P @230V input
Environment	Ta/Operation Temperature	-20....+50°C
	Ts/Storage Temperature	-20....+90°C
	Tc/Enclosure Temperature	90°C
	Humidity	10%....90%RH
	Atmosphere	86-108KPa
Construction	Connection Method	Push-in Terminal
	Installation	Build-in
	PRI Wire preparation	0.5-1.5 [□] / 8-9mm
	SEC Wire preparation	0.5-1.5 [□] / 8-9mm
	DALI Wire preparation	0.5-1.5 [□] / 8-9mm
	Dimension	128*30*21mm (L*W*H)
	Certification	CE/ENEC/SAA/UKCA/EAC
	Safety Standards	EN61347-1:2015/A1:2021; EN61347-2-13:2014/A1:2017; EN62384:2006/A1:2009; AS 61347.2.13:2018; AS/NZS61347.1:2016; BS EN61347-1:2015/A1:2021; BS EN61347-2-13:2014/A1:2017; IEC 61347-1:2015+A1:2017; IEC 61347-2-13:2014+A1:2016;
Standards	EMC Standards	AS/NZS CISPR 15:2011; AS CISPR 15:2017 ; BS EN IEC 55015:2019+A11:2020; EN 61547:2009; BS EN IEC 61000-3-2:2019; BS EN 61000-3-3:2013+A1:2019;
	Performance	EN 62384
	DALI Performance	EN 62386-101 (DALI-2) EN 62386-102 (DALI-2) EN 62386-207 (DALI-2, including part 251, 252, 253)
	Surge	L/N-Ground:2kV; L-N:1kV
Others	RoHS	2011/65/EU
	Life Time	50000h Tc=90°C
		75000h Tc=85°C
		100000h Tc=80°C
Warranty	5years , F.R. < 10000ppm	

Remark: 1.All Parameters, if not specified, are measured at 230VAC/50Hz and 25°C ambient temperature.
 2.LED Driver is a component of the luminaires, Luminaires and wire layout will affect the EMC, please check the EMC with end products again.
 3.Please make sure Tc under Lifetime condition when long term operate under DC input.
 4.Light output level in DC operation: (factory default = 100 %, EOfi = 1)

2. Label

KGP CC36W150-900 DALI LED Dimmable Driver
 KGP Electronics GmbH Constant Current LED Power Supply $t_c=90^\circ\text{C}$ $t_a=50^\circ\text{C}$
 Hueckstraße 19 PRI:220-240VAC 0/50/60Hz Max. 0.25A V-OUT:60VDC Max. 36W
 DE-58511 Lüdenscheid SEC:150-900mA 2.5-50VDC ●tc DC 180-280V

Pout [W]	Iout [mA]	λ	1	2	3	4	Pout [W]	Iout [mA]	λ	1	2	3	4
7.5	150	0.80C	-	-	-	-	27.5	550	0.88C	ON	-	-	-
10.0	200	0.81C	-	-	-	ON	30.0	600	0.89C	ON	-	-	ON
12.5	250	0.82C	-	-	ON	-	32.5	650	0.90C	ON	-	ON	-
15.0	300	0.83C	-	-	ON	ON	35.0	700	0.91C	ON	-	ON	ON
17.5	350	0.84C	-	ON	-	-	31.5	750	0.92C	ON	ON	-	-
20.0	400	0.85C	-	ON	-	ON	33.6	800	0.93C	ON	ON	-	ON
22.5	450	0.86C	-	ON	ON	-	35.7	850	0.94C	ON	ON	ON	-
25.0	500	0.87C	-	ON	ON	ON	36.0	900	0.95	ON	ON	ON	ON

Labels include: DALI 2, EL, ENEC, CE, UKCA, SELV, 110, and dimming symbols.

3. Output Current Setting

Output Current	1	2	3	4
150mA	-	-	-	-
200mA	-	-	-	ON
250mA	-	-	ON	-
300mA	-	-	ON	ON
350mA	-	ON	-	-
400mA	-	ON	-	ON
450mA	-	ON	ON	-
500mA	-	ON	ON	ON
550mA	ON	-	-	-
600mA	ON	-	-	ON
650mA	ON	-	ON	-
700mA	ON	-	ON	ON
750mA	ON	ON	-	-
800mA	ON	ON	-	ON
850mA	ON	ON	ON	-
900mA	ON	ON	ON	ON

4. Dimension (Unit: mm)

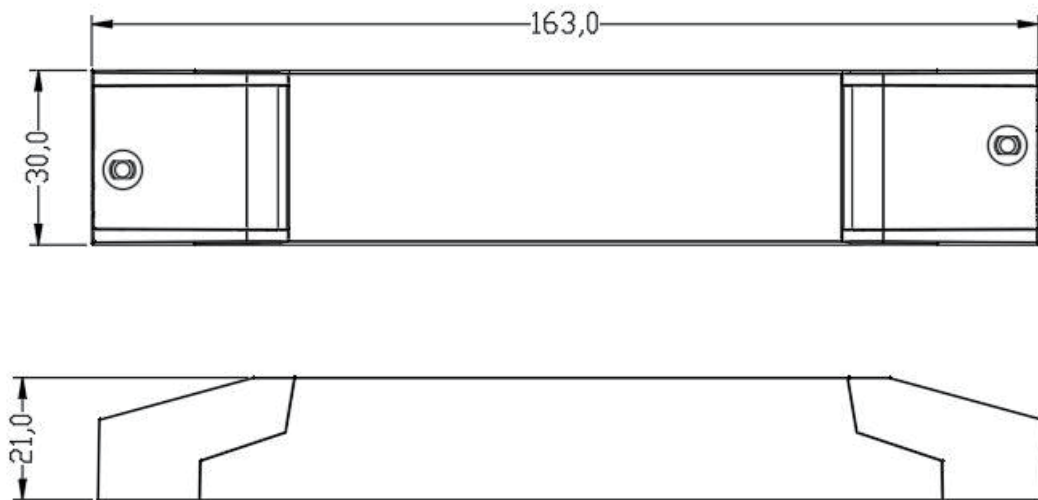

Built in type:

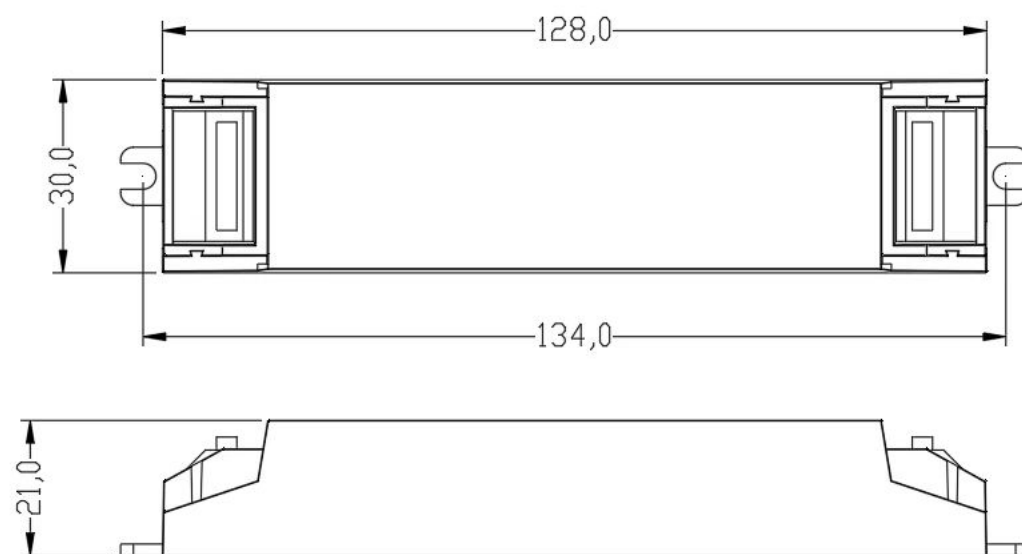

5. Wiring Diagram

Figure: Voltage peaks for LED driver without earthing (Above) and with earthing (Below)

220-240 V
0/50/60 Hz

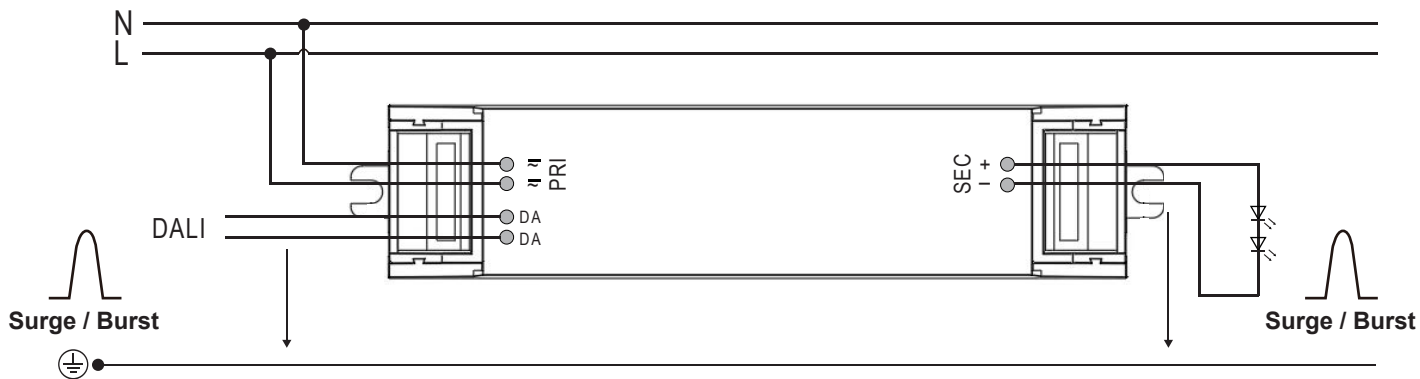

220-240 V
0/50/60 Hz

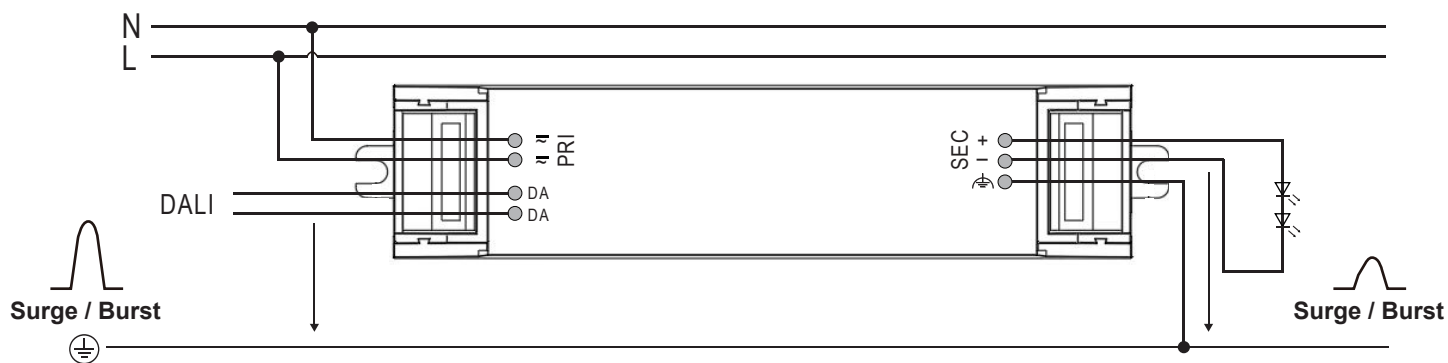

Push Dimming

Figure: Voltage peaks for LED driver without earthing (Above) and with earthing (Below)

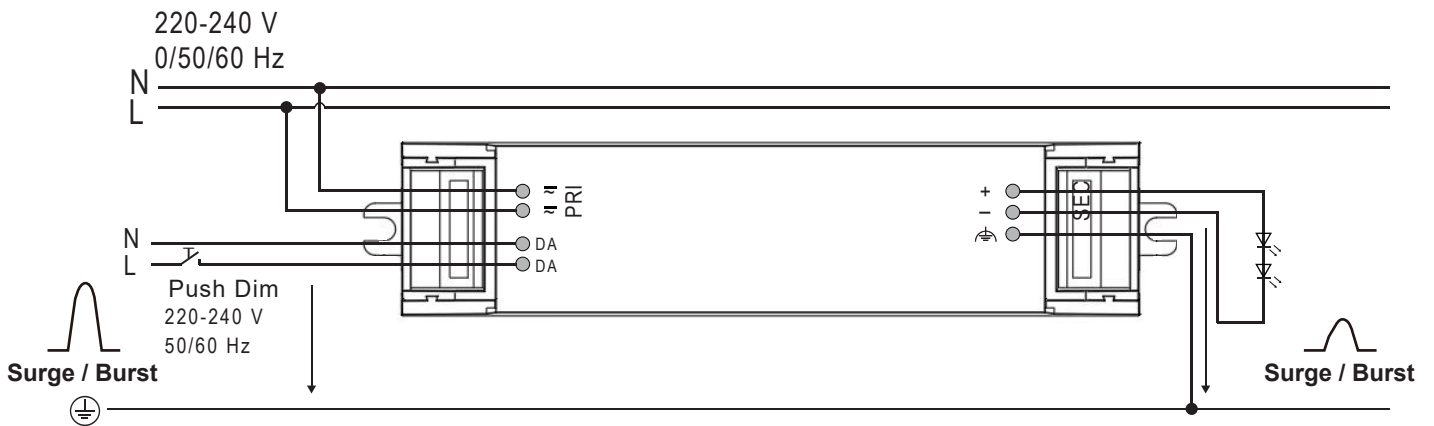
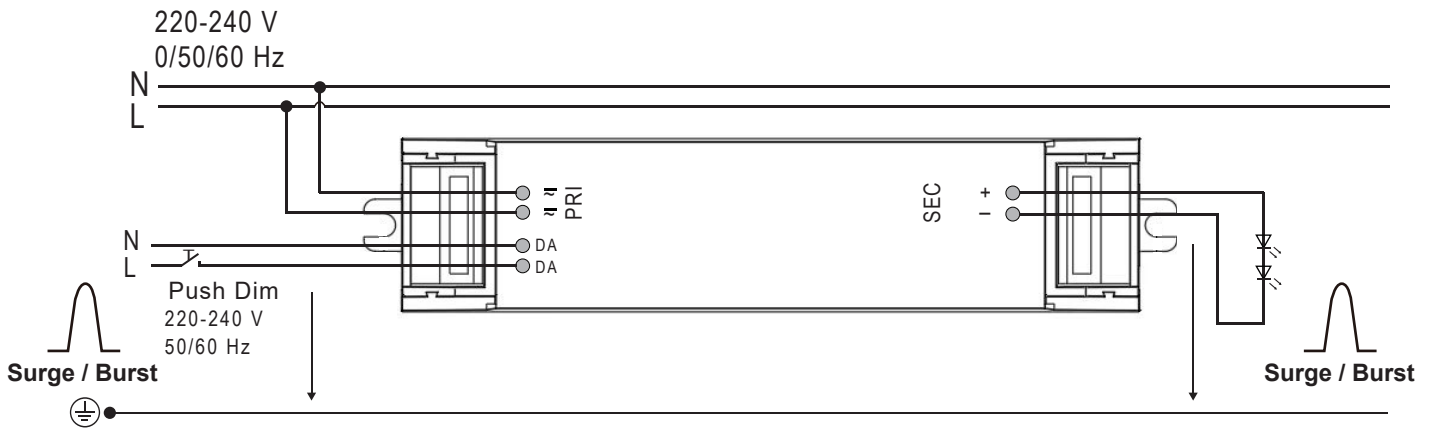

6. Output Power Window

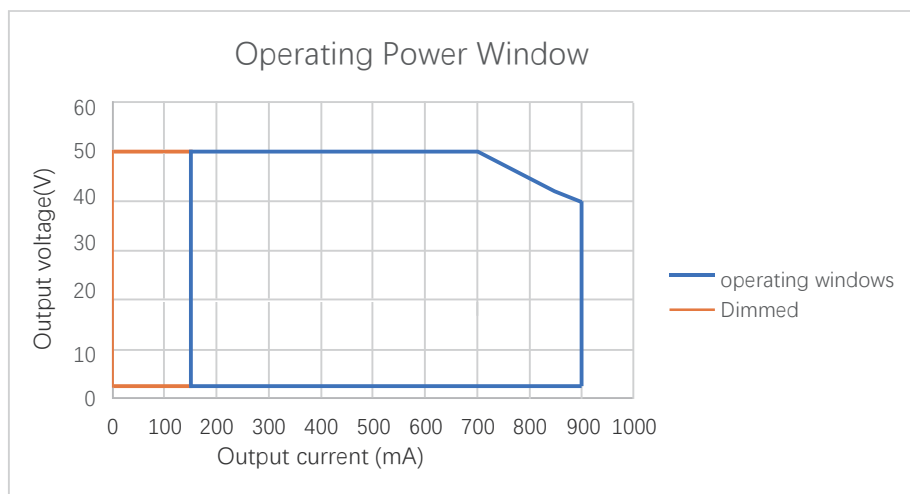

7. DALI dimming curve

formula for DALI dimming.

$$X(n) = 10^{\left\{ \left[\frac{(n-1)}{(253/3)} \right] - 1 \right\}}$$

Here, n means the target dimming stage of the total 254 stages.

X(n) means the percent of the maximum output current

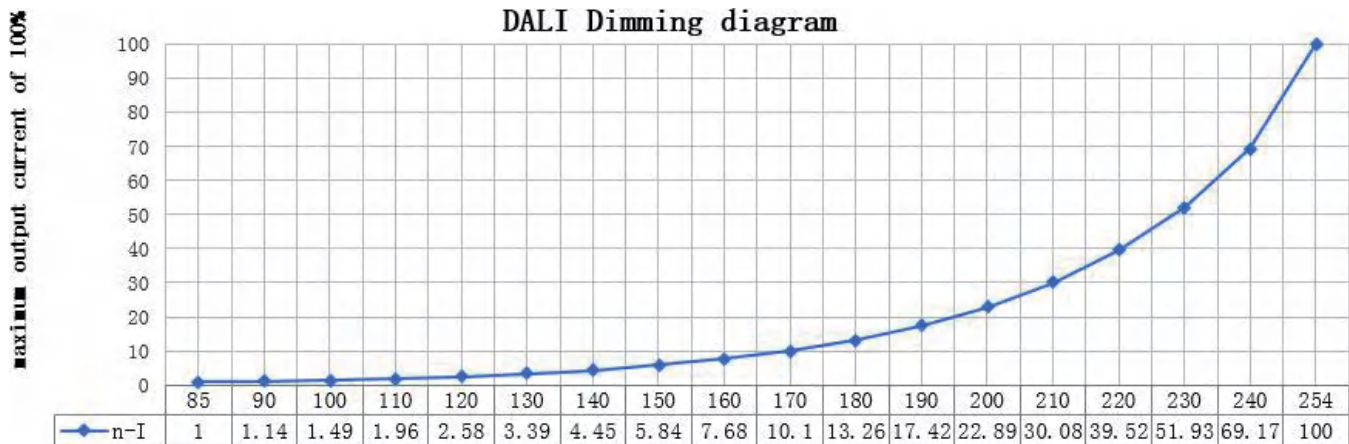

8. Packing information

SC

Carton L*W*H(mm)	Pcs/Carton	Net weight/ Pcs(kg)	Net weight/ Carton(kg)	Gross weight / Carton(kg)
T.B.D	T.B.D	T.B.D	T.B.D	T.B.D

Small side cover

Carton L*W*H(mm)	Pcs/Carton	Net weight/ Pcs(kg)	Net weight/ Carton(kg)	Gross weight / Carton(kg)
T.B.D	T.B.D	T.B.D	T.B.D	T.B.D

9. Function of the earth terminal:



The earth connection is conducted as protection earth (PE). The LED Driver can be earthed via earth terminal or metal housing (if device has metal housing). If the LED Driver will be earthed, protection earth (PE) has to be used. There is no earth connection required for the functionality of the LED Driver. Earth connection is recommended to improve following behaviour.

- Electromagnetic interferences (EMI)
- LED glowing at standby

In general, it is recommended to earth the LED Driver if the LED module is mounted on earthed luminaire parts respectively heat sinks and thereby representing a high capacity against earth.

Avoiding residual LED glow on standby

Residual LED glow on standby may occur as a result of capacitive leakage currents from the LED module onto earthed luminaire parts (such as the heat sink). This mainly affects high-efficiency LED systems with large surface areas installed in luminaires with protection class 1.

The topology has been improved so that residual LED glow can be virtually eliminated by earthing the devices.

10. Push Dim :

10.1 On / off:

Short push (120ms-600ms) on the switch

Stepless dimming: long push (> 0.6sec) on the switch

10.2 Power-on memory function

When the LED driver is powered on, it will restore the memory before the LED driver is powered off. (brightness remembers the brightness after the last dimming is stable, and the brightness during dimming is not memorized)

10.3 Light on/off

If the light is on, the light will be off after a short press. If the light is off, the light will be on after a short press. The time range of short press is 120-600mS.

10.4 PUSH Dimming

Press and hold the push switch for a long time, the light will enter the dimming state, if the previous time is dimming, it will automatically turn to dimming the next time. After releasing the reset button, the dimming stops and the current illuminance is maintained. The dimming range is 1%-100%. The default is to dim when the power is first long-press. If the brightness of the power-on is the maximum brightness, the first long-press is to dim. (Long press 0.6-3S to start dimming.)

10.5 Forced synchronization

Long press for 10 seconds to turn on all the lights and turn on the same brightness (50%), and continue to quickly short press will not change. After a short period of time without short press operation, the module exits the synchronization mode, and the short press restores the switch function.

10.6 PUSH Dimming rate

Long press the push switch 10S to switch the dimming rate to 3S, Long press the push switch 20S to switch the dimming rate to 6S, and it can also be changed by MAGIC or production software.

11. REVISION HISTORY

Date	Revision	Remark