

### Constant Current Driver

Model: CC23W100-700CG NFC



Model	Output Current	Input Current	Input Power	Output Power Range	PF	Efficiency (*Typical)	Output Voltage	No load Voltage
CC23W100-700CG NFC	100mA	0.035A	5.8W	0.25-4.6W	0.74	77%	2.5-46V	59V
	150mA	0.045A	8.4W	0.37-6.9W	0.83	80%	2.5-46V	59V
	200mA	0.054A	10.9W	0.50-9.2W	0.89	82%	2.5-46V	59V
	250mA	0.064A	13.4W	0.62-11.5W	0.92	84%	2.5-46V	59V
	300mA	0.074A	16.0W	0.75-13.8W	0.94	86%	2.5-46V	59V
	350mA	0.082A	18.4W	0.87-16.1W	0.96	86%	2.5-46V	59V
	400mA	0.095A	20.9W	1.00-18.4W	0.97	87%	2.5-46V	59V
	450mA	0.106A	23.5W	1.12-20.7W	0.97	87%	2.5-46V	59V
	500mA	0.116A	26W	1.25-23.0W	0.98	88%	2.5-46V	59V
	550mA	0.093A	20.5W	1.37-22.5W	0.97	86%	2.5-41V	59V
	600mA	0.10A	22.2W	1.50-22.8W	0.97	86%	2.5-38V	59V
	650mA	0.108A	24.1W	1.62-22.7W	0.98	86%	2.5-35V	59V
700mA	0.114A	25.7W	1.75-22.4W	0.98	86%	2.5-32V	59V	

\* Test result @230V, 50Hz, Full Load. Current setting @ 1mA-steps (NFC)

### 1. Parameters

Category	Item	Technical Norm
Features	Output Type	Constant Current
	Current Setting	Near field communication (NFC)
	Output Features	Isolation
	IP Grade	IP20
	Insulation Class	Class II
Input	Rated Input Voltage	220-240VAC
	Range of Input Voltage	176-264VAC
	Range of DC Input Voltage	180-280VDC
	Frequency	0/50/60Hz
	Input Current	≤0.16A max
	Input Power	≤29W max
	Power Factor	≥0.96 (230VAC , full load)
	THD	≤ 15% (230VAC , full load)

	No-load Power Consumption	≤0.5W (230VAC , DIM to off)
	Inrush Current	≤40A/15us (230VACfull load)
Output	Output Voltage Range	2.5-46VDC@100-500mA ; 2.5-41VDC@501-550mA ; 2.5-38VDC@551-600mA ; 2.5-35VDC@601-650mA ; 2.5-32VDC@651-700mA。
	No Load Voltage (Uout)	59VDC Max.
	Output Current	100-700mA (by NFC setting)
	Max. Output Power	23W
	Efficiency	≥88% (230VAC, 46VDC@500mA)
	Output LF current ripple (< 120 Hz)	±5% (Imax-Imin) / (Imax+Imin)
	Current Accuracy	±5%@ 301-700mA, ±10%@ 100-300mA
	Output PstLM (at full load)	≤ 1
	Output SVM (at full load)	≤0.4
	Starting Time	≤0.5S
	Control Method	Current Interface
NFC current setting		1mA-steps (NFC)
Protection	Short Circuit Protection	Auto Recovery
	Overload Protection	Auto Recovery (not be hot swap)
	No-load Protection	Auto Recovery
	Insulation voltage	3000V 5mA 60S between P-S
	Insulation resistance	>100M ohm @ 500VDC
	Leakage current	I/P to O/P <0.7mA
Environment	Ta/Operation Temperature	-25 ....+50°C
	Ts/Storage Temperature	-25 ....+85°C
	Tc/Enclosure Temperature	85°C
	Humidity	10%.... 90%RH
	Atmosphere	86- 108KPa
Construction	Connection Method	Push-in Terminal
	Installation	Built-in & Independent
	PRI Wire preparation	0.75- 1.5 <sup>□</sup> / 8mm
	SEC Wire preparation	0.5- 1.5 <sup>□</sup> / 8-mm
	Dimension	Independent: 138.7*31*21.5mm (L*W*H) Built-in: 118.3*31*21.5mm (L*W*H)
Standards	Certification	ENEC CE SAA EAC EL
	Safety Standards	EN 61347-1:2015/A1:2021 EN 61347-2-13:2014/A1:2017 EN IEC 62384:2020 EN 62493:2015/A1:2022 AS61347.2.13:2018 AS/NZS61347.1:2016 Inc A1
	EMC Standards	EN IEC 55015:2019 EN IEC 55015:2019/A11:2020 EN IEC 61000-3-2:2019/A1:2021 EN 61000-3-3:2013/A2:2021 EN IEC 61547:2023
	RED	EN 300 330 V2.1.1:2017

		EN 301 489-1 V2.2.3:2019 EN 301 489-3 V2.3.2:2023 EN 62479:2010 EN 50663:2017
	Performance	EN 62384
	Surge	L-N:2kV
Others	RoHS	2011/65/EU
	Life Time	50000h @Ta=50°C
	Warranty	5years , F.R. < 10000ppm
	Noise	≤ 24dB @Background noise ≤18dB ,Interval≥15cm

**Remark:**

- 1.All Parameters, if not specified, are measured at 230VAC/50Hz and 25°C ambient temperature.
- 2.LED Driver is a component of the luminaires, Luminaires and wire layout will affect the EMC, please check the EMC with end products again.
- 3.Do not install upside down.

### 2. Connected quantities of different current Breaker

TYPE	Connected quantities of different current Breaker						Input Voltage (V)	Inrush Current(A)	Time (µs)
	current (A)	10	13	16	20	25			
	Installation wire diameter	1.5mm <sup>2</sup>	2.5mm <sup>2</sup>	2.5mm <sup>2</sup>	4mm <sup>2</sup>	4mm <sup>2</sup>			
TYPE B	15	20	24	30	38	@230VAC	40	15	
TYPE C	24	31	38	48	60				
TYPE D	38	50	61	77	96				

### 3. Label

**KGP**  
KGP Electronics GmbH  
Hueckstraße 19  
DE-58511 Lüdenscheid

**LED Driver**  
**CC23W100-700CG NFC**  
Constant Current Type for LED only

wire preparation  
8mm   
PRI:0.75 -1.5<sup>□</sup>  
SEC:0.5 -1.5<sup>□</sup>

■ N PRI  
■ L II

Un=220-240V ≈  
IN= 0.13A Max.  
fn= 0/50/60Hz  
PF≥0.95  
ta:-25...50°C

●tc:85°C  
Iout= 100-700mA  
Uout= 2.5-46VDC  
Pout= 23W Max.  
No load= 59VDC Max.  
Current Setting by NFC,step 1 mA

### 4. Electrical values

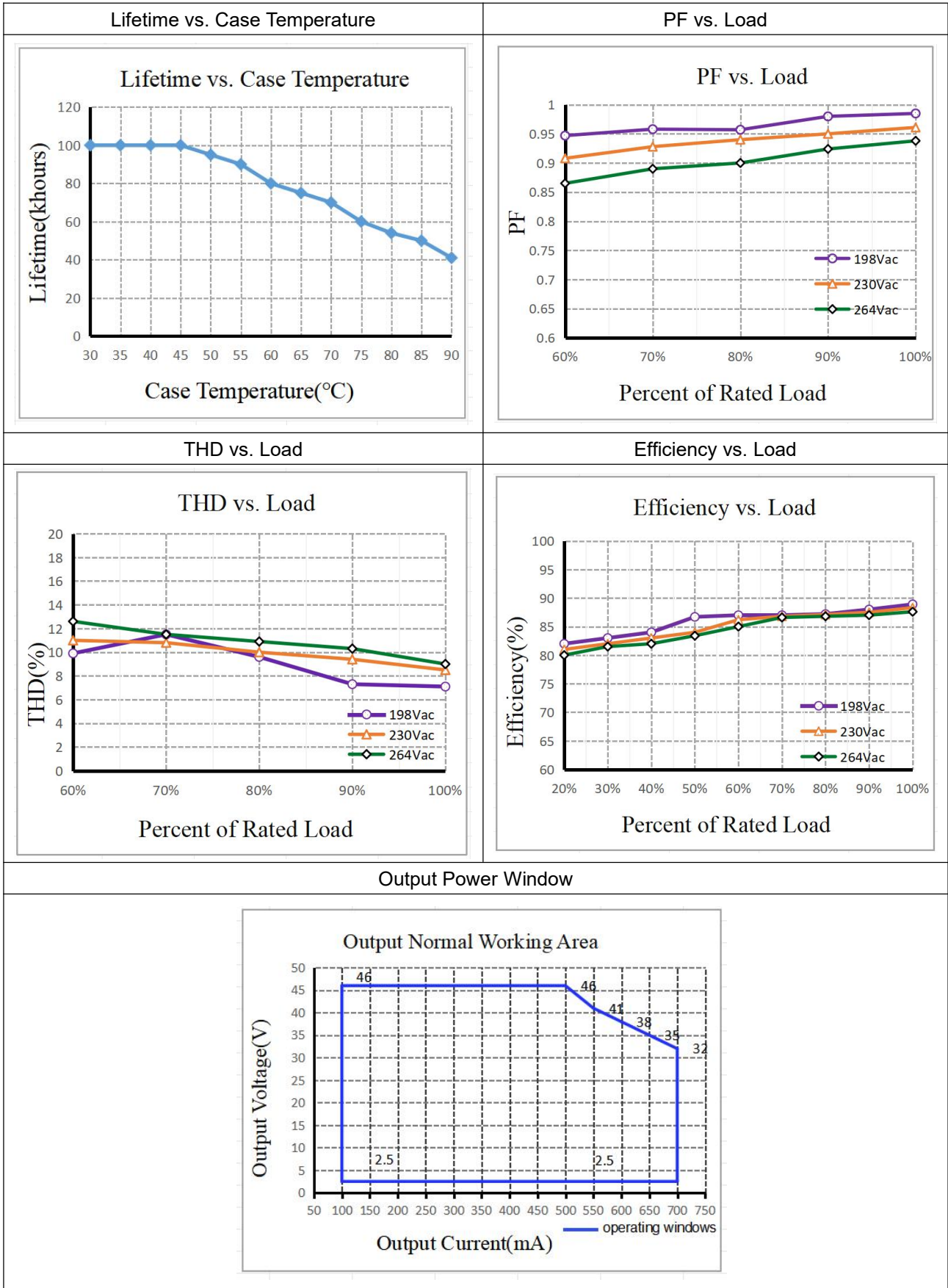

### 5. Dimension (Unit: mm)

Independent type :

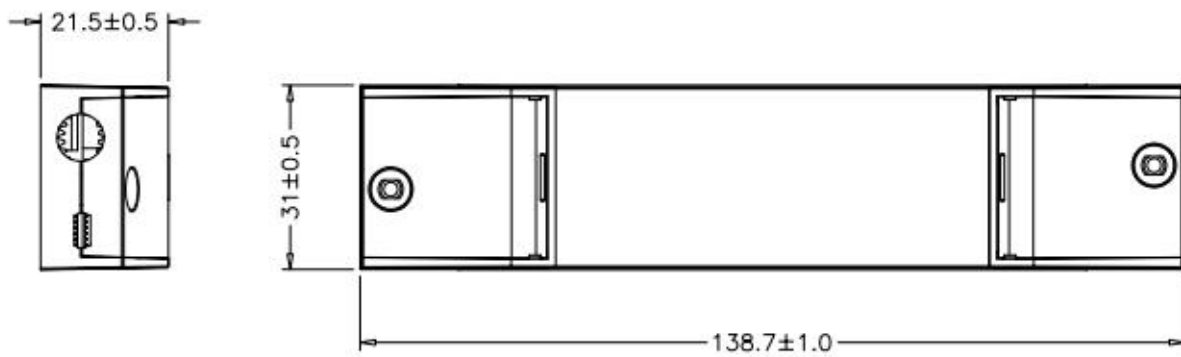

Built in type:

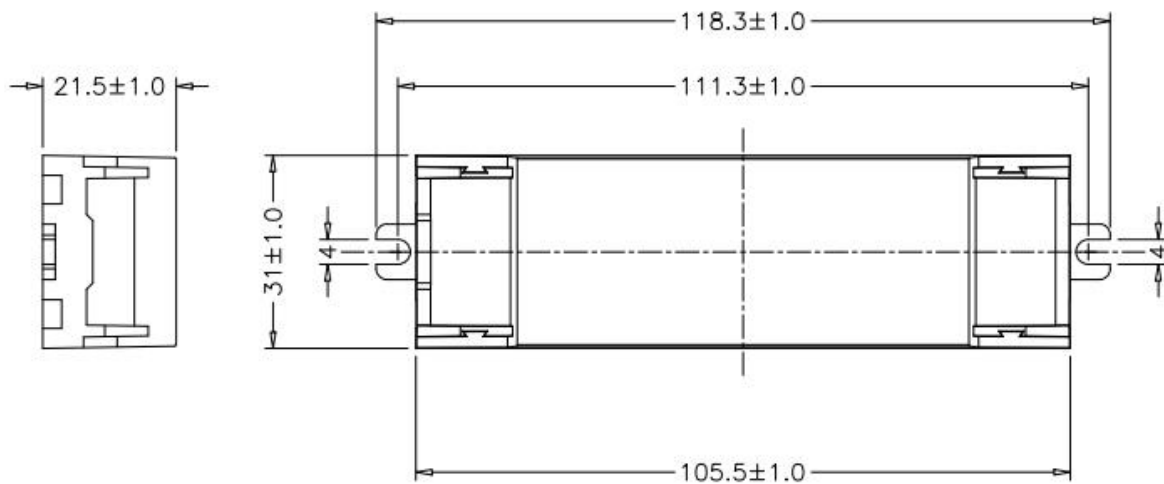

### 6. Wiring Diagram

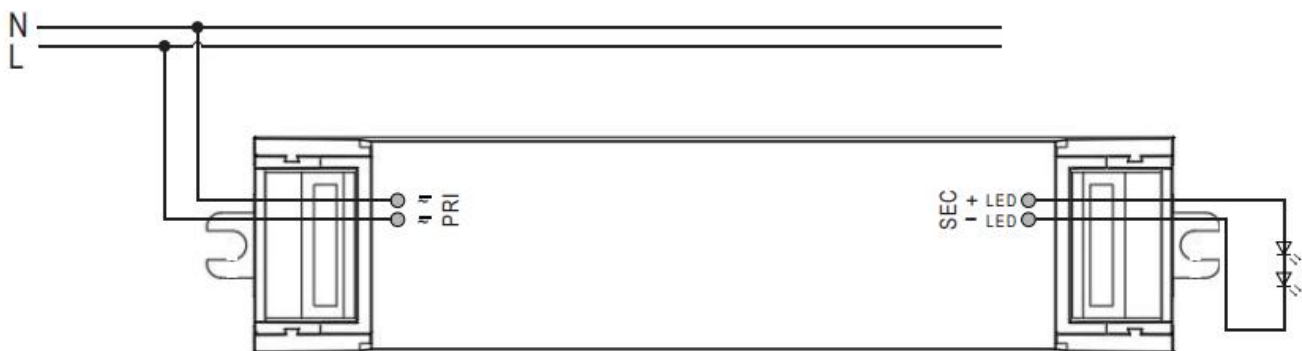

### 7. Packing information

Packing way	Model	Carton L*W*H(mm)	Pcs/ Carton	Net weight/ Pcs(kg)	Net weight/ Carton(kg)	Gross weight/ Carton(kg)
Built in (without white box and manual )	CC23W100-700 NFC	275*170*235	80	0.077	6.16	6.96
Independent (without white box and manual )	CC23W100-700CG NFC	370*185*245	100	0.089	8.9	9.46

### 8. Wiring instructions

- All connections must be kept as short as possible to ensure good EMI behaviour
- Mains leads should be kept apart from LED Driver and other leads (ideally 5 – 10 cm distance)
- Advice the maximum length of output wires is 3 m
- Secondary switching is not permitted ( Except for constant voltage )
- Incorrect wiring can damage LED modules.
- The wiring must be protected against short circuits to earth (sharp edged metals parts, metal cable clips, louver, etc.)
- Hot plug-in is not supported due to residual output voltage of > 0 V up to mains voltage. Danger to life.
- When connecting an LED load, restart the device to activate the LED output.
- This can be done via mains reset or via interface (DALI, DSI, switch DIM).

### 9. Replace LED module

- Mains off
- Remove LED module
- Wait for 30 seconds
- Connect LED module again
- Hot plug-in or secondary switching of LEDs is not permitted and may cause a very high current to the LEDs

### 10. REVISION HISTORY

DATE	VER	REMARK
2024-05-29	V1.0	Initial release
2025-11-06	V1.1	Update product labels