

Model	Output Current	Input Current	Input Power	Output Power Range	PF	Efficiency	Output Voltage	No load Voltage
CC21W150-500CG DALI-1	150mA	0.05A	9.8W	2.25-6.75W	0.75	80%	15-45V	59V Max
	200mA	0.068A	13.4W	3-9W	0.82	81%		
	250mA	0.082A	16.2W	3.75-11.25W	0.86	83%		
	300mA	0.094A	18.8W	4.5-13.5W	0.9	84%		
	350mA	0.11A	21.1W	5.25-15.7W	0.92	85%		
	400mA	0.12A	23.3W	6-18W	0.92	86%		
	450mA	0.13A	25.7W	6.75-20.25W	0.94	87%		
	500mA	0.133A	26.3W	7.5-21W	0.95	87%	15-42V	

* Test result @230V, 50Hz, Full Load.

1. Parameters

category	Item	Technical Norm
Features	Output Type	Constant Current
	Dimming Type	DALI-2 / Push DIM
	Output current setting	DIP
	Output Features	Isolation
	IP Grade	IP20
	Insulation Class	Class II
Input	Rated Input Voltage	220-240VAC
	Range of Input Voltage	198-264VAC or 180-280VDC
	Frequency	50/60Hz
	Input Current	≤0.133A (230VAC ,full load)
	Input Power	≤26.3W (230VAC ,full load)
	Power Factor	≥0.95 (230VAC ,full load)
	THD	≤10% (230VAC ,full load)
	Standby Power Consumption	≤0.5W @230VAC
Output	Output Voltage	15-45VDC@150-450mA
		15-42VDC@500mA
	No Load Voltage	59VDC Max.
	Output Current	150- 500mA (Max. output)

CC21W150-500CG DALI-1

Output	Max. Output Power	21W
	Efficiency	≥87% (230VAC ,full load@max current)
	Current Ripple(≤120HZ)	±5% (Imax-Imin) / (Imax+Imin)
	Current Accuracy	±5%
	PSTLM	≤ 1
	SVM	≤0.4
	Starting Time (AC mode)	≤1S (230VAC ,full load)
	Starting Time (DC mode)	≤1S
Control Method	PUSH dimming	PUSH dimming (Max. lead wire length:20m,same port of DALI)
	PUSH-button	Max parallel connections qty for Push-dim 15 PCS
	DALI function	DALI dimming (Max. lead wire length:300m) Logarithm or linear dimming curve selectable 251,252,253 EL(EMI not evaluated),CLO,Corridor mode.
	Dimming range	DALI dimming: 1%- 100%,Dim to off
Protection	Short Circuit Protection	Auto Recovery
	Overload Protection	Auto Recovery
	No-load Protection	Auto Recovery
	Insulation voltage	3000V 5mA 60S between P-S
	Insulation resistance	>100M ohm @ 500VDC
	Leakage current	< 700μA, O/P to PE @240V/60HZ input
Environment	Ta/Operation Temperature	-25+45°C
	Ts/Storage Temperature	-25+85°C
	Tc/Enclosure Temperature	85°C
	Humidity	10%.... 90%RH
	Atmosphere	86- 108KPa
Construction	Connection Method	Push-in Terminal
	Installation	Built in & Independent
	PRI Wire preparation	0.5- 1.5 □
	SEC Wire preparation	0.5- 1.5 □
	DALI Wire preparation	0.5- 1.5 □
	Dimension	Built in:97.5*44*23mm (L*W*H) Independent-Small side cover :137.6*44*23mm (L*W*H) Independent-Large side cover :191.6*44*23mm (L*W*H)
Standards	Certification	CE
	Safety Standards	EN 61347-1:2015/A1:2021 EN 61347-2-13:2014/A1:2017 EN IEC 62384:2020 EN 62493:2015
Standards	EMC Standards	EN IEC 55015:2019 EN IEC 55015:2019/A11:2020 EN IEC 61000-3-2:2019/A1:2021 EN 61000-3-3:2013/A2:2021 EN IEC 61547:2023

CC21W150-500CG DALI-1

	Performance	EN62384:2020
	DALI performance	EN 62386- 101 (DALI-2) EN 62386- 102 (DALI-2) EN 62386-207 (DALI-2, including part 251, 252, 253)
	Surge	L-N/2KV
Others	RoHS	2011/65/EU
	Life Time	50000h@Ta
	Warranty	5years , F.R. < 10000ppm
	Audible Noise	<22dB @ 20cm distance, 15dB background

Remark:

- All Parameters, if not specified, are measured at 230VAC/50Hz and 25°C ambient temperature.
- LED Driver is a component of the luminaires, Luminaires and wire layout will affect the EMC, please check the EMC with end products again.
- Please make sure Tc under Lifetime condition when long term operate under DC input.
Light output level in DC operation: (factory default = 100 %, EOFi = 15%).
- During the PUSH DIM test, the number of parallel connections must be less than 15PCS.

2. Connected quantities of different current Breaker

TYPE	Connected quantities of different current Breaker						Input Voltage	Inrush Current(A)	Time(μs)
	current (A)	10	13	16	20	25			
	Installation wire diameter	1.5mm ²	2.5mm ²	2.5mm ²	4mm ²	4mm ²			
TYPE B		13	17	21	27	33	@230VAC	45	36
TYPE C		21	28	34	43	53			
TYPE D		34	44	55	68	85			

3. Label



KGP
KGP Electronics GmbH
Hueckstraße 19
DE-58511 Lüdenscheid

CC21W150-500CG DALI-1
Constant Current LED Dimmable Driver ta:45°C tc:85°C
PRI:220-240VAC 50/60Hz 0.133A Max.
SEC:150-450mA 15-45VDC 500mA 15-42VDC
Uout:Max.59VDC For LED modules Only

ON
OFF



wire preparation 8-9mm



PRI:0.5-1.5[□]
DALI:0.5-1.5[□]
SEC:0.5-1.5[□]





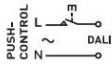

PRI: L, N, DA, DA









DIM: L, N, DALI



Pout [W]	Iout [mA]	λ	1	2	3	Pout [W]	Iout [mA]	λ	1	2	3
6.75	150	0.78C	-	-	-	15.7	350	0.92C	-	-	ON
9.0	200	0.84C	ON	-	-	18.0	400	0.92C	ON	-	ON
11.25	250	0.88C	-	ON	-	20.25	450	0.94C	-	ON	ON
13.5	300	0.90C	ON	ON	-	21.0	500	0.95	ON	ON	ON







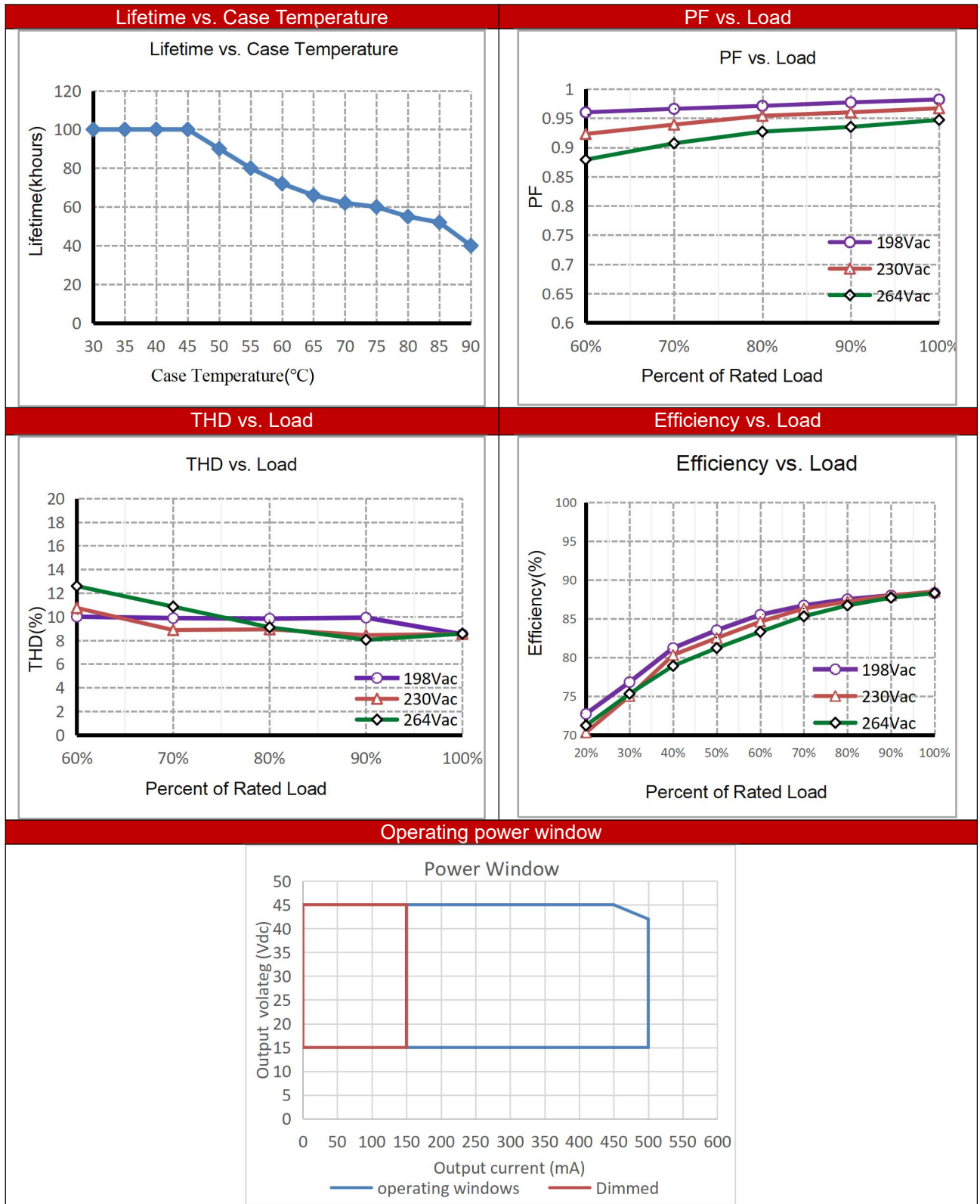

4. Electrical values

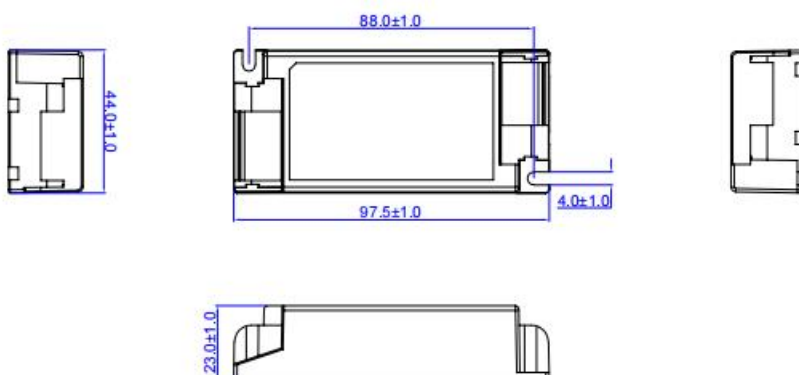

5. Dimension SC(A):



Small side cover(B) :

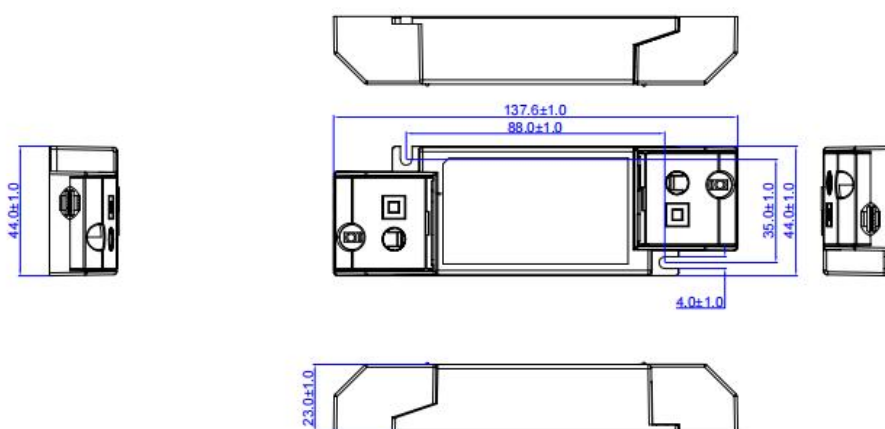

Large side cover(C):

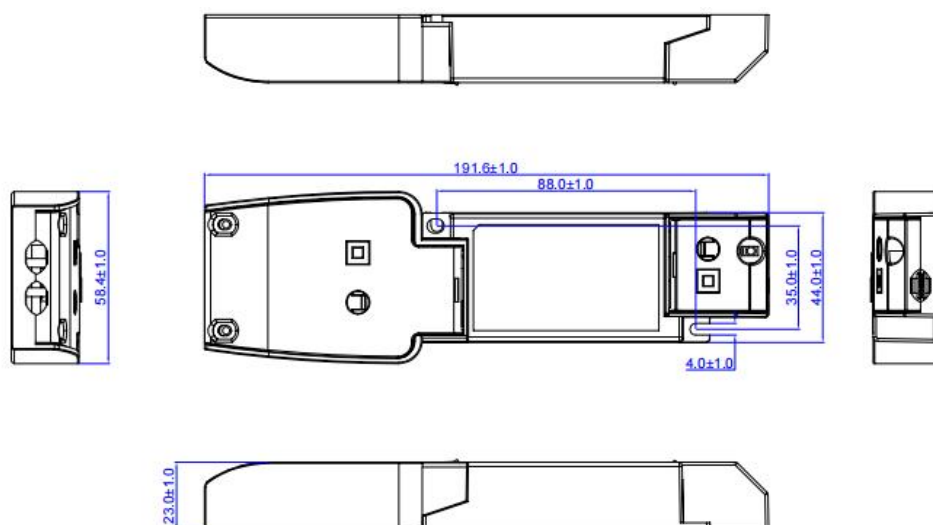

6. Wiring Diagram

Fig. A: Push Dimming

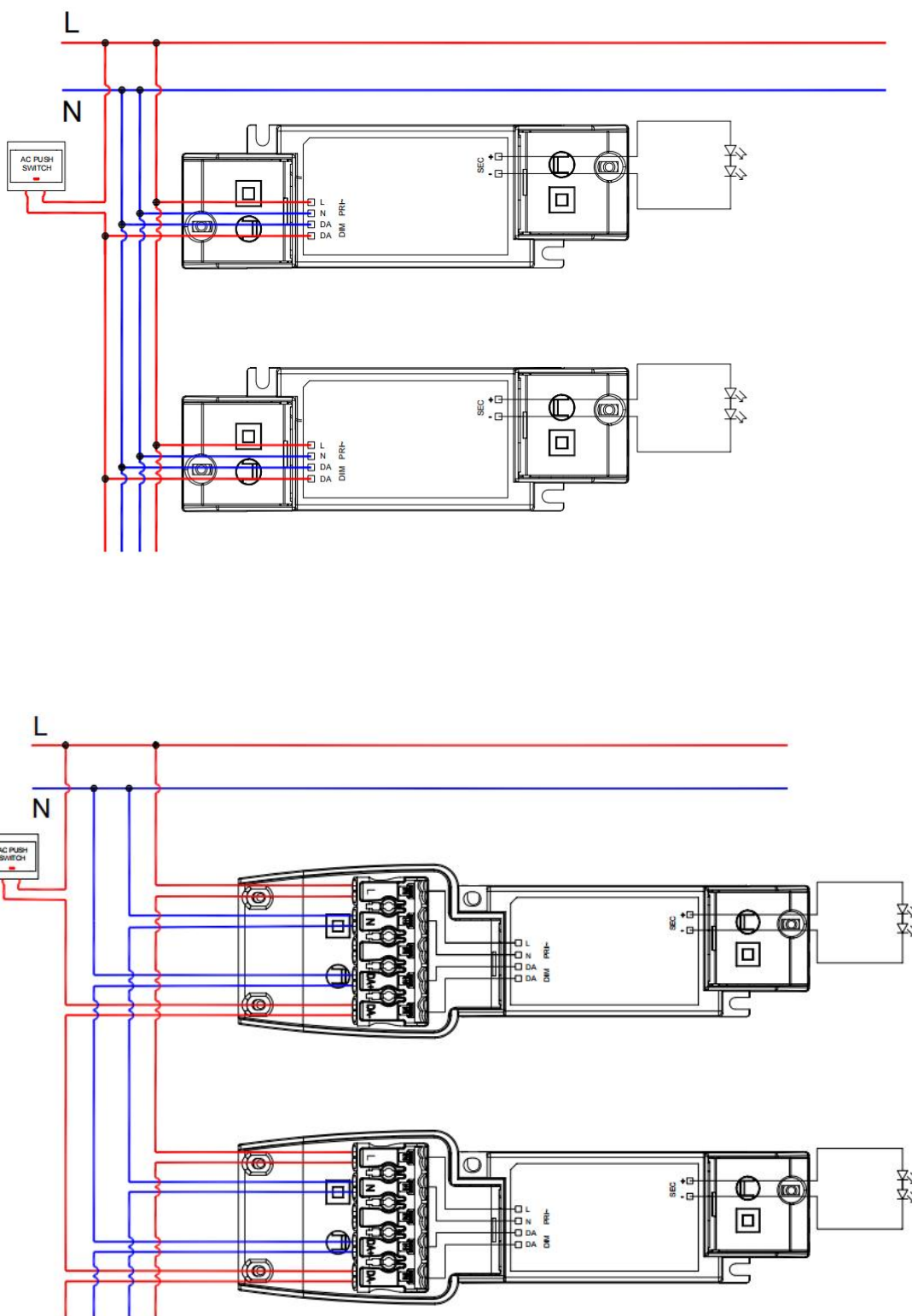
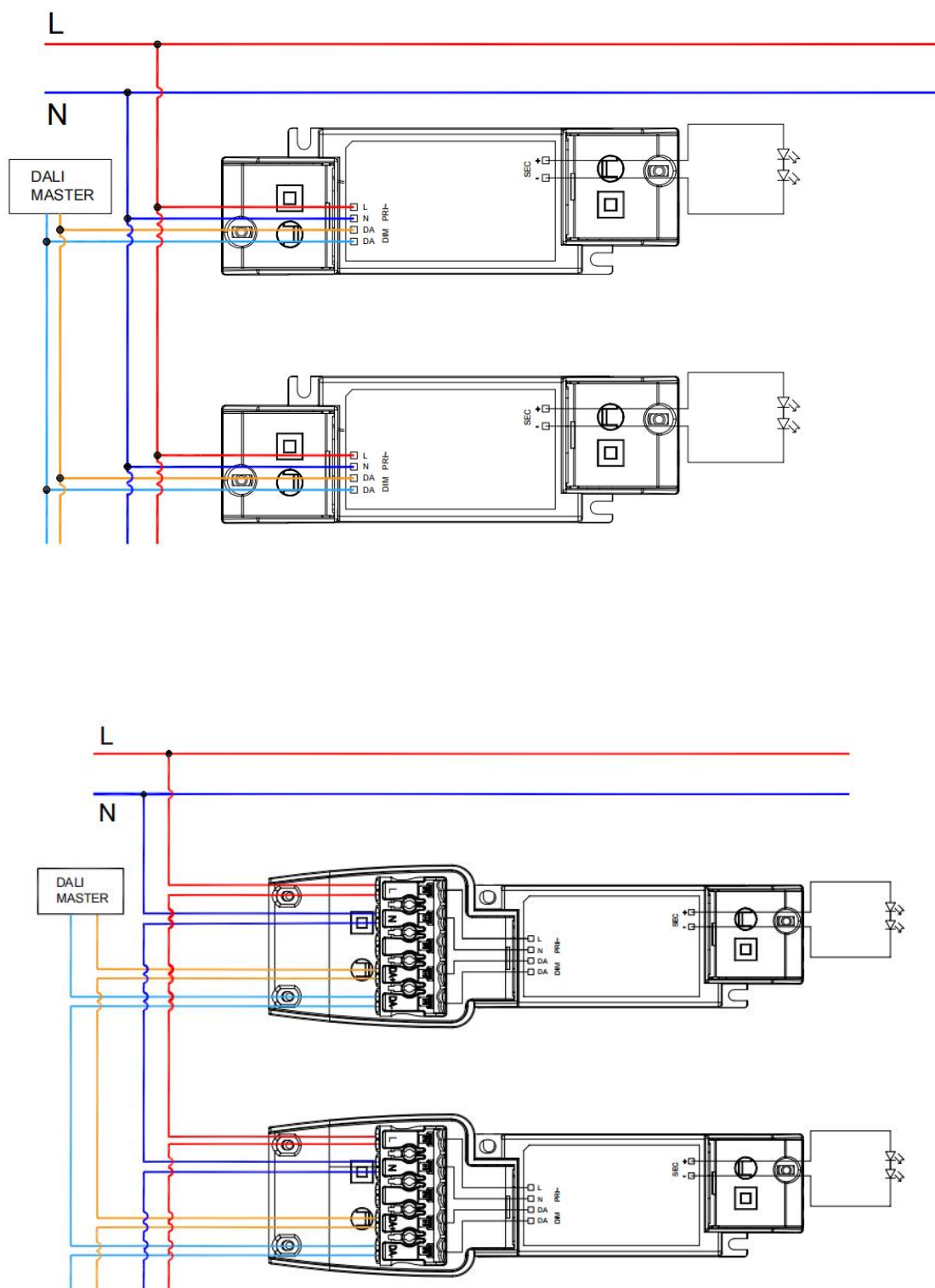

Fig. B: DALI Dimming



7. DALI dimming curve

formula for DALI dimming.

$$X(n)=10^{\{[(n-1)/(253/3)]-1\}}$$

Here, n means the target dimming stage of the total 254 stages.

X(n) means the percent of the maximum output current

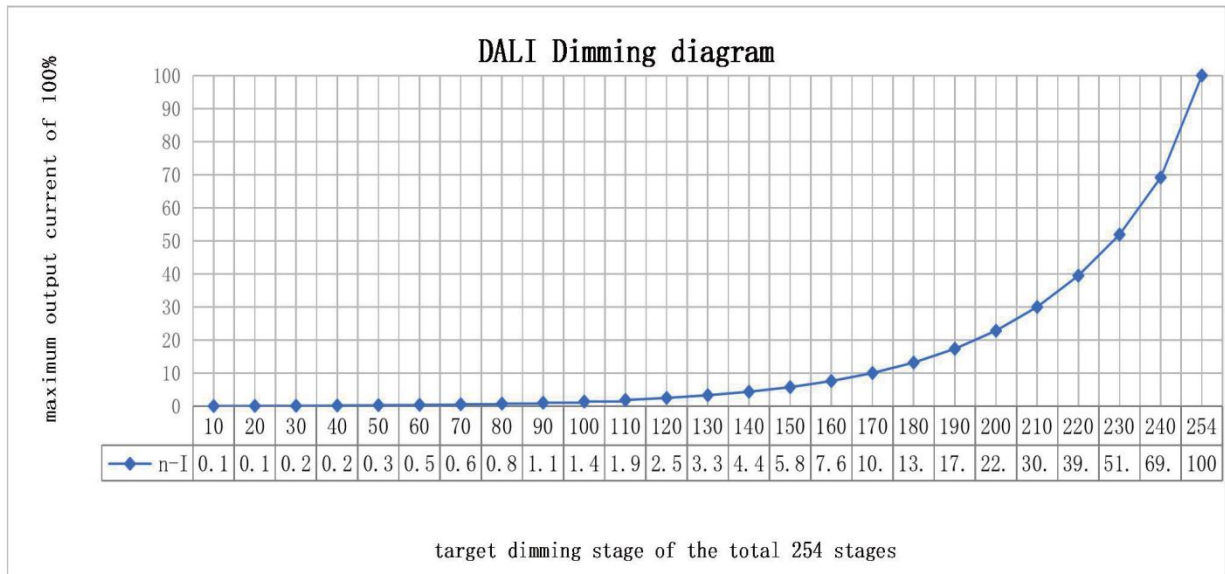

8. Packing information

SC(A)

Packing way	Model	Colour	Carton L*W*H(mm)	Pcs/ Carton	Net weight/ Pcs(kg)	Net weight/ Carton(kg)	Gross weight/ Carton(kg)
industrial	CC21W150-500CG DALI-1	White	457*250*220	80	0.097	7.76	8.46

Small side cover(B)

Packing way	Model	Colour	Carton L*W*H(mm)	Pcs/ Carton	Net weight/ Pcs(kg)	Net weight/ Carton(kg)	Gross weight/ Carton(kg)
industrial	CC21W150-500CG DALI-1	White	457*250*220	80	0.115	9.17	9.87

Large side cover(C)

Packing way	Model	Colour	Carton L*W*H(mm)	Pcs/ Carton	Net weight/ Pcs(kg)	Net weight/ Carton(kg)	Gross weight/ Carton(kg)
industrial	CC21C150-500CG DALI-1	White	457*250*220	80	0.137	11	11.7

9. Functions

9.1 OEM Identification

The OEM (Original Equipment Manufacturer) can set his own identification number.
DALI Part 251: Memory bank 1 extension.

9.2 OEM GTIN

The Original Equipment Manufacturer (OEM) can set his own Global Trade Item Number (GTIN).
DALI Part 251: Memory bank 1 extension.

9.3 Luminaire data

This function provides the asset management with accurate data about the luminaire.
DALI Part 251: Memory bank 1 extension.
DALI Part 253: Luminaire maintenance data.

9.4 Switch DIM

Integrated Switch DIM function allows a direct connection of a push button for dimming and switching.
Brief push (< 0.6 s) switches LED driver ON and OFF. The dim level is saved at power-down and restored at power-up. When the push button is held, LED modules are dimmed. After repush the LED modules are dimmed in the opposite direction.
In installations with LED drivers with different dimming levels or opposite dimming directions (e.g. after a system extension), all LED drivers can be synchronized to 50 % dimming level by a 10 s push.
Use of push button with indicator lamp is not permitted.

More functions:

Action	Action duration	Function
Short push	<0.6s	Turn on/off
Short push five times	<3s	Quit Corridor mode
Long push	0.6-3s	Dimming up or down
Long push	10s	Sync all LEDs to be 50% brightness, and the dimming rate is changed to 3S
Long push	20s	Dimming rate is changed to 6S
Long push	>2mins	Enter Corridor mode - LED keep 100% brightness for 2mins.

9.5 Corridor FUNCTION

With the Corridor FUNCTION and a commercially available motion detector, it is easy to adapt the lighting in one area to its use.
That is, when the area is entered by a person, the lighting dims instantly to the desired brightness and is available in full strength.
After the area is left by the person, the brightness dims slowly to a smaller value or switches off completely.
The individual parameters of the desired profile, such as brightness values or delay times, can be adjusted flexibly and individually.

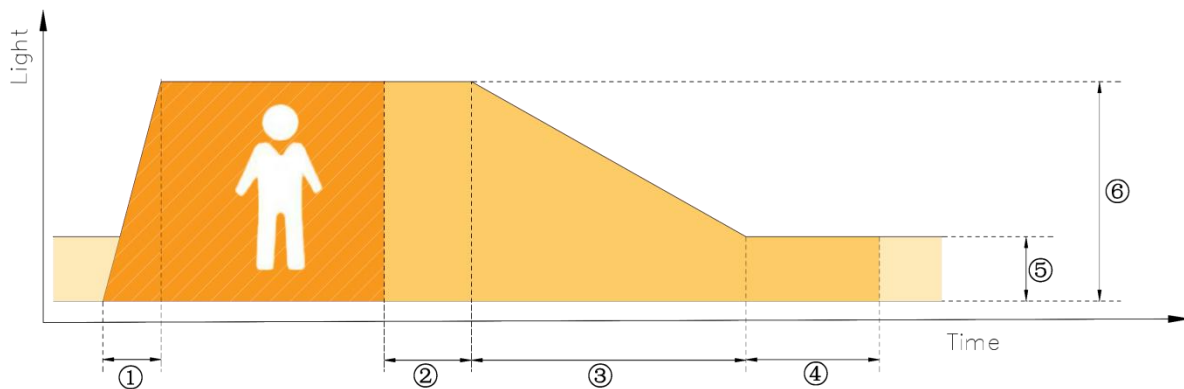

- ① Fade-in time(1s): the time that starts as soon as the presence of a person is detected. During the fade-in time the luminous intensity is faded up to the presence value.
- ② Run-on time(120s): the time that starts as soon as the presence of a person is no longer detected. If the presence of a person is detected again during the run-on time the run-on time is restarted from zero. If no presence is detected during the run-on time the fade time is started as soon as the run-on time expires.
- ③ Fade time(32s): the time during which the luminous intensity is faded from the presence value to the absence value.
- ④ Switch-off delay(Never Off): the time during which the absence value is held before the lighting is switched off. Depending on the profile selected the switch-off delay may have different values or may not be defined.
- ⑤ Absence value(default: 10 %): the luminous intensity when there is no person present.
- ⑥ Presence value (default: 100 %): the luminous intensity when persons are present.

9.6 Constant Light Output (CLO)

With this function the light output of the LED module can be kept equal over the lifetime.

The light output of an LED module reduces over the course of its lifetime.

The Constant Light Output (CLO) function compensates for this natural decline by constantly increasing the output current of the LED driver throughout its lifetime.

CLO shall be achieved by limitation of the LED current at the commissioning of the LED driver and providing a linear interpolation of the current over the time, depending on the data points given by the user.

The user has to insert up to eight pairs of data (time, level).

The output curve is the result of connecting the user data points linear.

Detailed description for CLO see product manual.

The minimal CLO starting point is limited by the smallest output current of the LED driver.

9.7 Dimming curve

DALI:The desired dimming behaviour is selected via two different dimming curves (logarithmic or linear).

DALI:The desired dimming behaviour is selected via two different dimming curves (logarithmic or linear).

The default setting of the dimming behaviour is logarithmic.

10. Revision History

Date	Revision	Remark
2024-5-21	V1.0	preliminary version