

		2.5-25VDC@600mA
		2.5-22VDC@700mA
	No Load Voltage	59VDC Max.
	Output Current	100mA -700mA
	Max. Output Power	15W
	Efficiency	≥85% (230VAC, full load)
	Current Ripple(< 120 Hz)	±5% (Imax-Imin)/(Imax+Imin)
	PstLM	≤1
	SVM	≤0.4
	Current Accuracy	±5% (@300-700mA) ±8% (@100-200mA)
	Started Delay Time	≤1S(230VAC, full load)
Control Method	Dimming range	CASAMBI dimming: 1%-100% ,Dim to off .
	NFC current setting	The output current can be set within the total value range in 1-mA-steps.Output current is mean value. Setting is by KGP's software APP/APK/PC with FEIG equipment or mobile phone.
Protection	Short Circuit Protection	Auto Recovery
	Overload Protection	Auto Recovery
	No-load Protection	Auto Recovery
	Insulation voltage	3000V 5mA 60S between P-S
	Insulation resistance	>100M ohm @ 500VDC
	Leakage current	< 250µA, I/P to O/P or I/P to PE @230V input
Environment	Ta/Operation Temperature	-20....+50°C
	Ts/Storage Temperature	-35....+85°C
	Tc/Enclosure Temperature	85°C
	Humidity	10%....90%RH
	Atmosphere	86-108KPa
Construction	Connection Method	Direct Lead
	Installation	Built-in
	Dimension	64.5*40*23mm (L*W*H)
Standards	Certification	CE
	Safety Standards	EN 61347-1:2015/A1:2021 EN 61347-2-13:2014/A1:2017 EN IEC 62384:2020 EN 62493:2015 AS61347.2.13:2018 AS/NZS61347.1:2016 Inc A1
	EMC Standards EMC	EN IEC 55015:2019 EN IEC 55015:2019/A11:2020 EN IEC 61000-3-2:2019/A1:2021 EN 61000-3-3:2013/A2:2021 EN 61547:2009
	Performance	EN62384:2020
	Surge	L-N/1KV
	Others	RoHS

	Life Time	50000h @Ta
	Warranty	5years ,F.R. < 10000ppm
	Noise	≤ 24dB @Background noise ≤18dB , Interval≥15cm

Remark:

1. All Parameters, if not specified, are measured at 230VAC/50Hz and 25°C ambient temperature.
- 2.LED Driver is a component of the luminaires, Luminaires and wire layout will affect the EMC, please check the EMC with end products again.

2. Connected quantities of different current Breaker

TYPE	Connected quantities of different current Breaker						Input Voltage	Inrush Current (A)	Time
	current (A)	10	13	16	20	25			
	Installation wire diameter	1.5mm ²	2.5mm ²	2.5mm ²	4mm ²	4mm ²			
TYPE B		9	12	15	18	23	@230VAC	65	200US
TYPE C		15	19	24	30	37			
TYPE D		24	31	38	47	59			

3. Label

+
 -
SEC



KGP Electronics GmbH
Hueckstraße 19
DE-58511 Lüdenscheid

LED Dimmable Driver
CC15W100-700 CAB NFC-1
 For LED modules only

UN=220-240VAC	Uout=2.5-45VDC
IN=0.11A Max.	Iout=100-700mA const
fN=50/60Hz	Pout=15W Max.
PF≥0.92C	No load=60VDC Max.
ta=50°C tc=85°C	●tc















PRI~
 L N





4. Electrical values

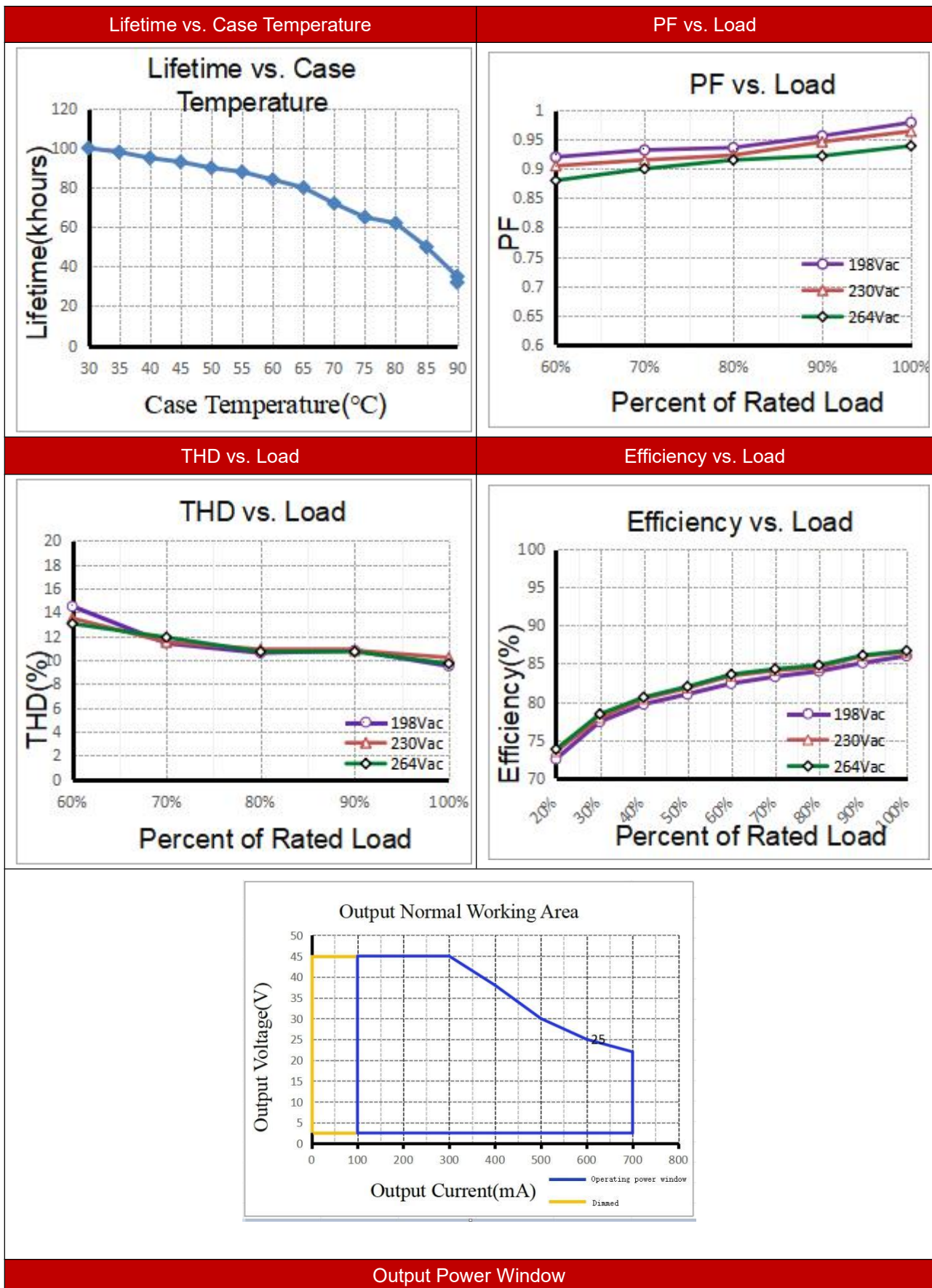

5. Dimension

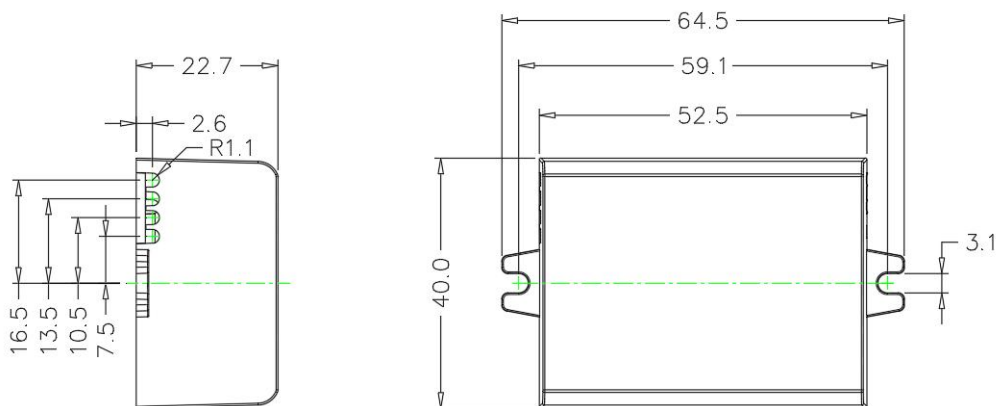

6. Packing information

Packing way	Model	Colour	Carton L*W*H(mm)	Pcs/ Carton	Net weight/ Pcs(kg)	Net weight/ Carton(kg)	Gross weight/ Carton(kg)
industrial	CC15W100-700 CAB NFC-1	White	L420*W280*H210	160	0.065	10.4	11.9

7. Wiring Diagram

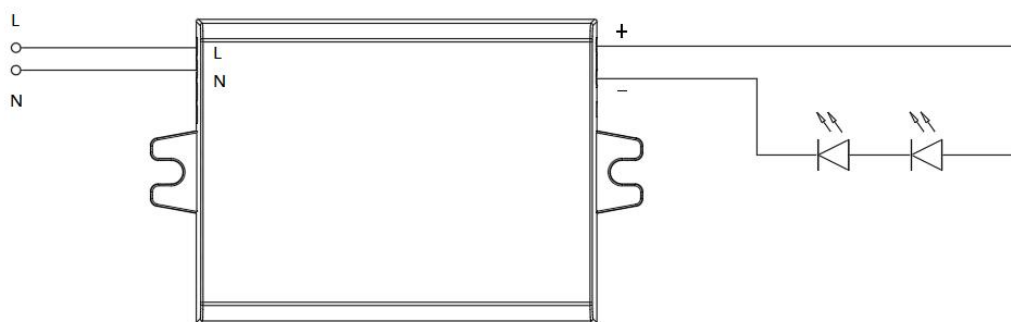

8. Wiring instructions

- All connections must be kept as short as possible to ensure good EMI behaviour
- Mains leads should be kept apart from LED Driver and other leads (ideally 5 – 10 cm distance)
- Advice the maximum length of output wires is 3 m
- Secondary switching is not permitted (Except for constant voltage)
- Incorrect wiring can damage LED modules.
- The wiring must be protected against short circuits to earth (sharp edged metals parts, metal cable clips, louver, etc.)
- Hot plug-in is not supported due to residual output voltage of > 0 V up to mains voltage. Danger to life.
- When connecting an LED load, restart the device to activate the LED output.

9. REVISION HISTORY

DATE	REV	Modification details
2024-8-27	V1.0	Initial release.