



# BNC Series

## BNC

BNC (**B**ayonet **N**avy **C**onector) series is one of the most popular coaxial connectors. The BNC incorporates a bayonet lock interface, which provides rapid and reliable intermateability. The impedance of the BNC connector is 50 or 75 ohms both versions will mate together without any restrictions. Respectively with impedance 50 or 75 ohms, BNC connectors can be operated up to 4GHz or 1GHz. This connector range is suitable for the standard types of flexible & semi-rigid cables, and it is also available as a flange or PCB mounted version.

### Applications:

\*telecommunication devices \*medical equipment \*monitor \*LANs \*test instrumentation

### Interface dimensions conformable to the Standards:

International: IEC 169-8

USA: MIL-C-39012

BNC 50Ω Interface Dimensions:

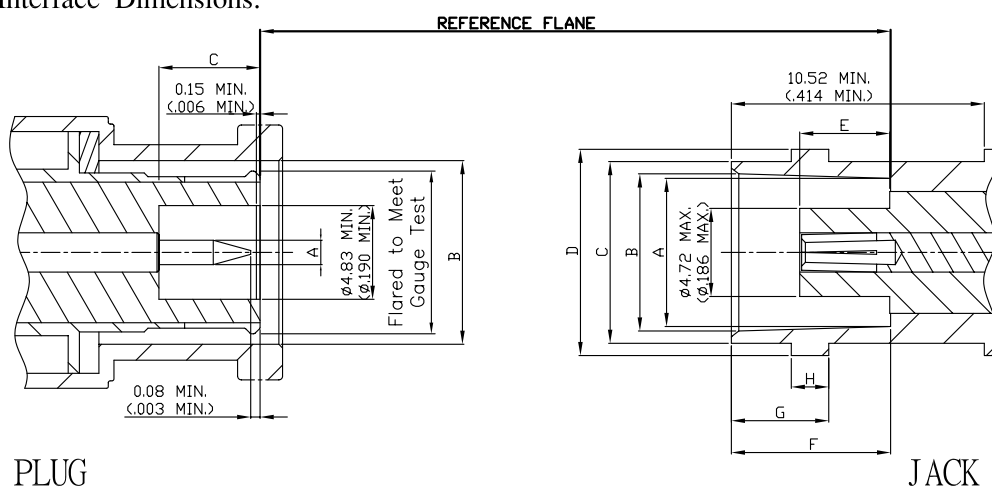

BNC Series						
PLUG			JACK			
	Minimum	Maximum		Minimum	Maximum	
A	1.32(.052)	1.37(.054)		8.10(.391)	8.15(.321)	A
B	9.78(.385)	9.91(.390)		8.31(.327)	8.46(.333)	B
C	5.28(.208)	5.79(.228)		9.60(.378)	9.70(.382)	C
				10.97(.432)	11.07(.436)	D
				4.72(.186)	5.23(.206)	E
				8.31(.327)	8.51(.335)	F
				5.18(.204)	5.28(.208)	G
				1.91(.075)	2.06(.081)	H

\*Millimeters(Inches)



Materials :

Connector part	Material	Finish
Bodies	Brass	Nickel or Gold
Center Contact	Male: Brass Female: Brass, Phosphor Bronze, or Beryllium Copper	Gold
Insulator	Delrin or Teflon	N/A
Crimp ferrule	Annealed Copper	Nickel or Gold

Electrical :

Electrical Data	Detail	
Impedance	50 ohm	75 ohm
Frequency range	0-4 GHz	0-1 GHz
Working voltage	500 volts rms max.	
Insulation resistance	5,000 megohms min.	
Dielectric withstanding voltage	1,500 volts rms min.	
Contact resistance	Center contact: 1.5 Milliohms Outer contact: 1.0 Milliohms	
VSWR: f (GHz)	Straight: 1.3 max. Right angle: 1.5 max.	
Insertion loss	0.2 dB max. at 3GHz	

Mechanical :

Mechanical Data	Detail
Engagement force	2.5 inch-pound max.
Disengagement force	3 lbs max. Axial force
Connector durability	500 cycles min.
Cable retention force	RG58, 141, 142, 223/U → 40 lbs min. RG174, 188, 316/U → 20 lbs min.

Environmental :

Environmental Data	Detail
Corrosion (Salt spray)	MIL-STD-202 METHOD 101 TEST CONDITION B
Thermal shock	MIL-STD-202 METHOD 107 TEST CONDITION B
Vibration	MIL-STD-202 METHOD 204 TEST CONDITION B
Mechanical shock	MIL-STD-202 METHOD 213 TEST CONDITION I
Temperature range	-65 to 165 (Teflon)

## BNC STRAIGHT CLAMP FOR FLEXIBLE CABLE

### PLUG

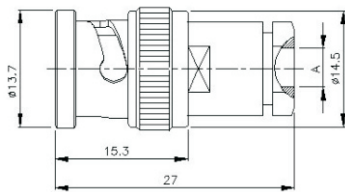

PART NUMBER:  
 BNC-01B-TGN           RG-213/U  
 BNC-01F-TGN           RG-58/U  
 BNC-01G-TGN(75Ohm) RG-59/U

### JACK

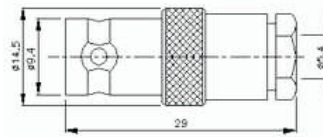

PART NUMBER:  
 BNC-03B-TGN           RG-213/U  
 BNC-03F-TGN           RG-58/U  
 BNC-03G-TGN(75Ohm) RG-59/U

## BNC STRAIGHT PLUG CRIMP FOR CABLE TYPE

### CRIMP FOR FLEXIBLE CABLE

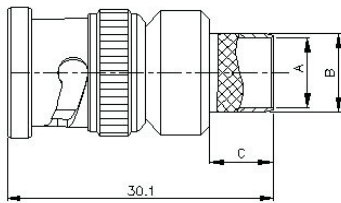

PART NUMBER:  
 BNC-05B-TGN           RG-213/U  
 BNC-05C-TGN           RG-214/U  
 BNC-05D-TGN(75Ohm) RG-11/U  
 BNC-05S-TGN           LMR-400

### SOLDER FOR SEMI-RIGID CABLE

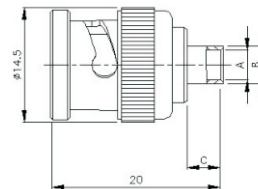

PART NUMBER:  
 BNC-05V1-TGN       RG-405/U(.085")  
 BNC-05V2-TGN       RG-402/U(.141")

## BNC PLUG CRIMP FOR FLEXIBLE CABLE

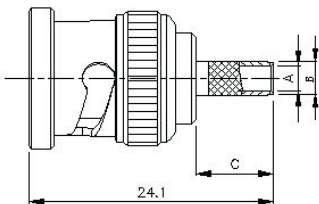

PART NUMBER:  
 BNC-05L-TGN(DGN)(-RP) RG-174/U

PART NUMBER:  
 BNC-05A-TGN(75Ohm)    RG-11/U  
 BNC-05G-TGN(75Ohm)    RG-59/U  
 BNC-05GV2-TGN(75Ohm) TELLU-13  
 BNC-05V1F-TGN(75Ohm) BT3002/FLEX2  
 BNC-05N-TGN(75Ohm)    RG-179/U  
 BNC-05V1D-TGN(75Ohm) FLEX-5  
 BNC-05V2L-TGN(75Ohm) 1.5C2V

PART NUMBER:  
 BNC-05R-TGN            LMR-240  
 BNC-05F-TGN(DGN)      RG-58/U  
 BNC-05FA-TGN           RG-142/U,400/U  
 BNC-05P-TGN            RG-223/U  
 BNC-05LV5-TGN         RD-316/U  
 BNC-05L-TGN            RG-174/U  
 BNC-05S1-TGN          LMR-200  
 BNC-05M-TGN            RG-178/U  
 BNC-05U-TGN            HRS-1.3 CABLE

## BNC STRAIGHT JACK CRIMP FOR FLEXIBLE CABLE

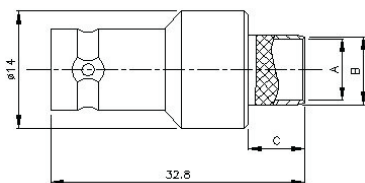

PART NUMBER:  
 BNC-07B-TGN           RG-213/U  
 BNC-07C-TGN           RG-214/U

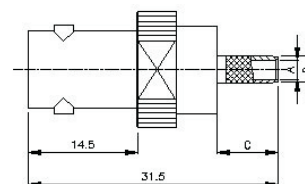

PART NUMBER:  
 BNC-07FV1-TGN         RG-58/U  
 BNC-07L-TGN            RG-174/U  
 BNC-07G-TGN(75Ohm)   RG-59/U  
 BNC-07P-TGN            RG-223/U

BNC



## BNC STRAIGHT CLAMP FOR FLEXIBLE CABLE

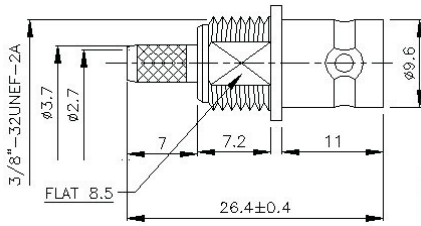

PART NUMBER:  
 BNC-15L-TGN(-RP) RG-174/316/L  
 BNC-15LV5-TGN(-RP) RG-316/U

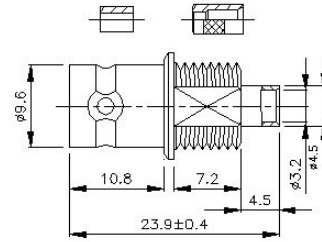

PART NUMBER:  
 BNC-15LV1-TGN-1 RG-174/U  
 BNC-15NV1-TGN-1(75Ohm) RG-179/U  
 BNC-15NV5-TGN-1(75Ohm) RD-179/U

## BNC PLUG TWIST ON

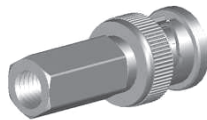
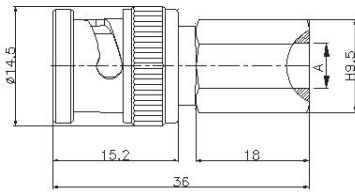

PART NUMBER:  
 BNC-09F-DGN  
 BNC-09G-DGN(75Ohm)

## BNC JACK TWIST ON

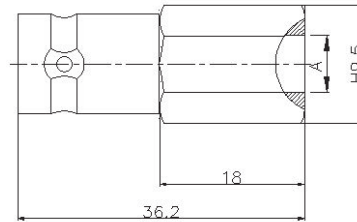

PART NUMBER:  
 BNC-10F-DGN  
 BNC-10G-DGN(75Ohm)

## BNC JACK PCB MOUNT RECEPTACLE

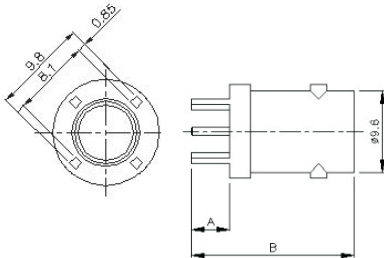

PART NUMBER:

	A	B
BNC-11-TGN(-RP)	4.5	17.9
BNC-11V4-TGN(-RP)	4.5	23.2
BNC-11V5-TGN(-RP)	7.45	20.85
BNC-11V6-TGN(-RP)	4.5	32.7
BNC-11V8-TGN(-RP)	5	31.8

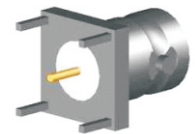
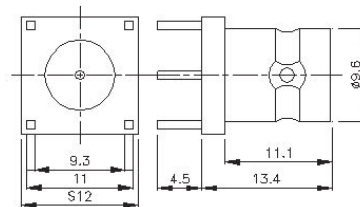

PART NUMBER:  
 BNC-12-TGN  
 BNC-12-TGN-75(75Ohm)  
 BNC-12-TGN-RP

## BNC RIGHT ANGLE JACK PCB MOUNT

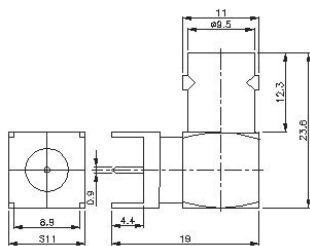

PART NUMBER:  
 BNC-13-TGN  
 BNC-13V4-TGN  
 BNC-13V5-TGN

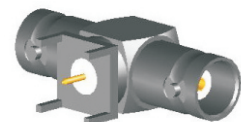
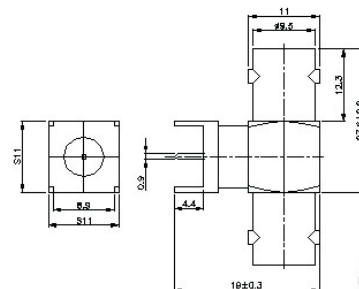

PART NUMBER:  
 BNC-56-TGN



### BNC PLUG - N JACK ADAPTOR

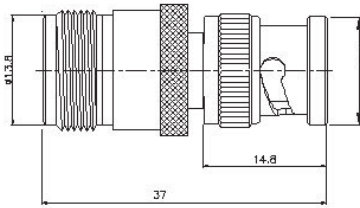

PART NUMBER:  
BNC-25-DGN

### BNC PLUG -TNC JACK ADAPTOR

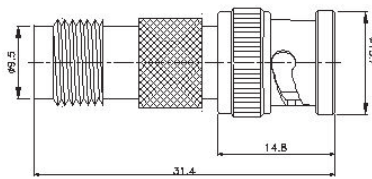

PART NUMBER:  
BNC-26-DGN

### BNC PLUG -F JACK ADAPTOR

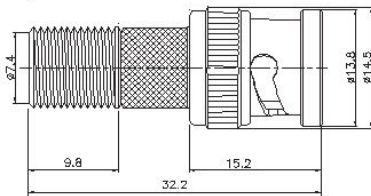

PART NUMBER:  
BNC-27-DGN

### BNC PLUG -UHF JACK ADAPTOR

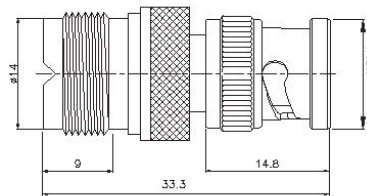

PART NUMBER:  
BNC-28-DGN

### BNC PLUG - RCA JACK ADAPTOR

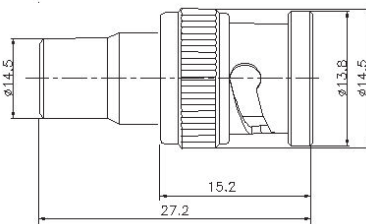

PART NUMBER:  
BNC-29-DGN

### BNC PLUG - F PLUG ADAPTOR

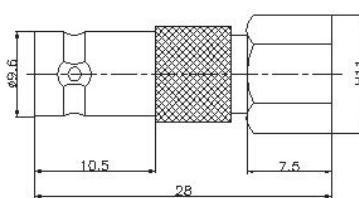

PART NUMBER:  
BNC-30-DGN

### BNC PLUG -F JACK ADAPTOR

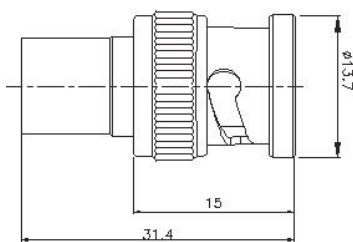

PART NUMBER:  
BNC-46-DGN

### BNC PLUG -UHF JACK ADAPTOR

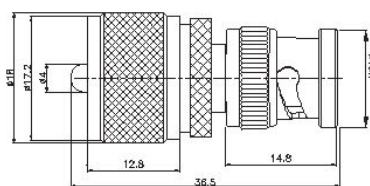

PART NUMBER:  
BNC-30-DGN

BNC



BNC

### BNC JACK - JACK ADAPTOR

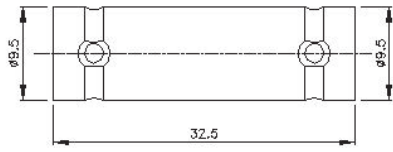

PART NUMBER:  
BNC-20-DGN  
BNC-20-DGN-75(75Ohm)

### BNC PLUG- PLUG ADAPTOR

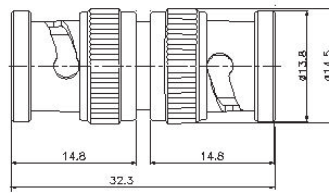

PART NUMBER:  
BNC-22-DGN

### BNC PLUG - JACK ADAPTOR

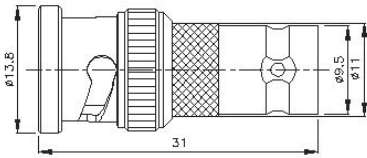

PART NUMBER:  
BNC-47-DGN  
BNC-47-DGN-75(75Ohm)

### BNC ANGLE PLUG - JACK ADAPTOR

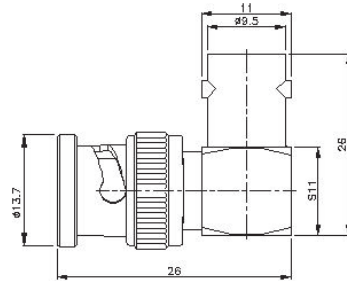

PART NUMBER:  
BNC-23-DGN  
BNC-23-DGN-75(75Ohm)

### BNC PLUG- JACK - PLUG ADAPTOR

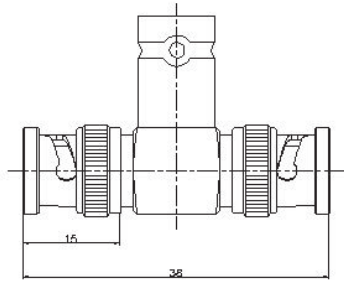

PART NUMBER:  
BNC-51-DGN

### BNC JACK-JACK-PLUG ADAPTOR

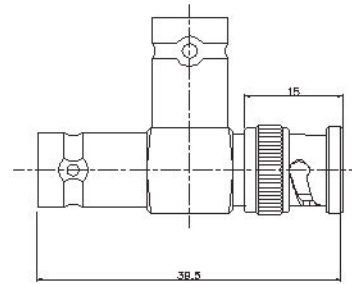

PART NUMBER:  
BNC-45-DGN

### BNC JACK-PLUG-JACK ADAPTOR

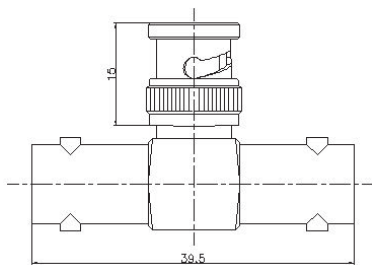

PART NUMBER:  
BNC-24-DGN

### BNC JACK-JACK-JACK ADAPTOR

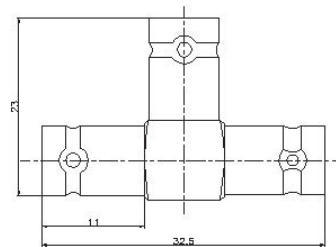

PART NUMBER:  
BNC-21-DGN

## BNC PLUG - JACK - JACK ADAPTOR

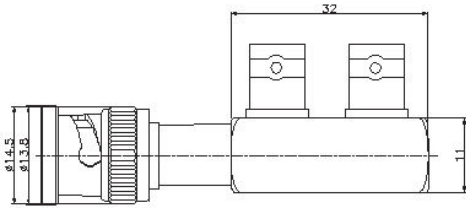

PART NUMBER:  
BNC-35-DGN

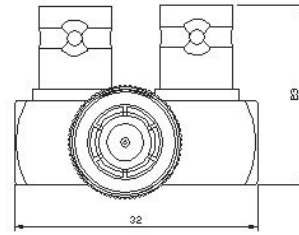

PART NUMBER:  
BNC-38-DGN

## BNC PLUG - UHF JACK ADAPTOR

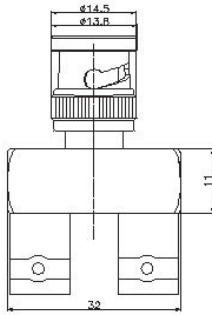

PART NUMBER:  
BNC-42-DGN

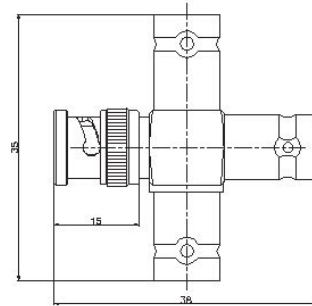

PART NUMBER:  
BNC-63-DGN

## BNC PLUG - RCA JACK ADAPTOR

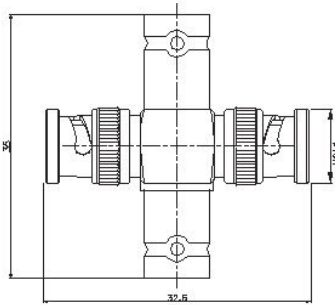

PART NUMBER:  
BNC-65-DGN

## BNC PLUG - F PLUG ADAPTOR

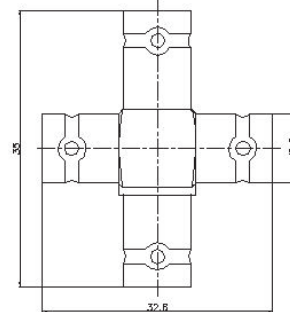

PART NUMBER:  
BNC-62-DGN

BNC

