

NO	DESCRIPTION	MATERIAL	Q'TY	FINISH	REMARK
1	BODY 1	BRASS	1	NICKEL	B-BNC0184-N
2	INSULATION	TEFLON	1	TEFLON	I-0172T
3	GASKET	SI RUBBER	1	RUBBER	RU-0010
4	WASHER 1	BRASS	1	NICKEL	W-0026-N
5	WASHER 2	BRASS	1	NICKEL	W-0027-N
6	WASHER 3	BRASS	1	NICKEL	W-0025-N
7	BODY 2	BRASS	1	NICKEL	B-TNC0085-N
8	PIN	BRASS	1	GOLD	P-TNC0222-G
9	RING	BRASS	1	NICKEL	R-0007-N

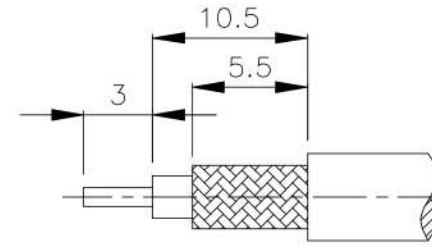

(Recommended Stripping Dimension)

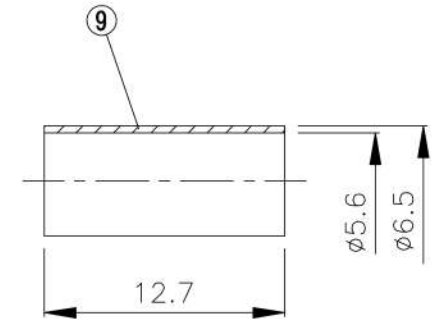
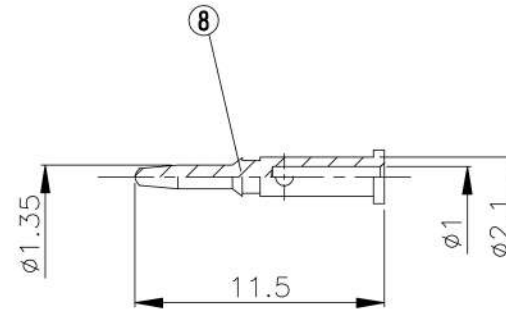
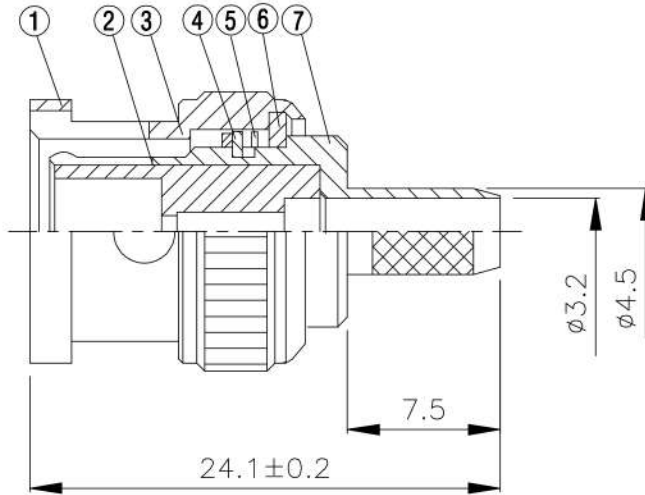
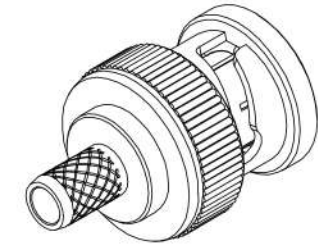

Nominal voltage: 500V

	<b>HUS-TSAN GROUP CO., LTD.</b> P.O. BOX 40-76. TAINAN. TAIWAN, R.O.C.		DRAWN	MARY	DATE	94.02.24	DIMENSIONS ARE IN MILLIMETERS		REVISION		
	TITLE		BNC MALE CRIMP FOR RG/58U	CHECKED	蘇姿潔	DATE		UNLESS OTHERWISE SPECIFIED TOLERANCE		DESCRIPTION	ENGINEER
	PART NO.		BNC-05F-TGN	Q.A.	馮健華	DATE		0.5-5 = ±0.2	120-315 = ±1		
	DRAWING NO.		BNC 05F TGN	APPROVAL	徐燦霖	DATE		5-30 = ±0.4	315-1000 = ±1.6		
				REVISION		DATE		30-120 ±0.6	1000-2000 = ±2.4		
							SCALE	4:1	SIZE	A	