

AT-41CD2 CRYSTAL UNIT

PN: AT-41CD2-4MHz S1-4085-3030-16

FEATURES

- DIMENSION (mm) : 12.5 X 4.70 X 4.20T
- METAL WELDED PACKAGE
- RoHS COMPLIANT

SPECIFICATIONS

	Item	Conditions	Specifications
1	HOLDER TYPE	HC-49/SM	AT-41CD2
2	FREQUENCY RANGE	MHz	4MHz
3	OSCILLATION MODE		Fundamental
4	FREQUENCY TOLERANCE	AT +25±3°C	±30ppm
5	FREQUENCY STABILITY	PPM	±30ppm
6	OPERATING TEMPERATURE RANGE	°C	-40 ~ +85°C
7	STORAGE TEMPERATURE RANGE	°C	-40 ~ +85°C
8	EQUIVALENT SERIES RESISTANCE	ESR (Ω)	150Ω
9	LOAD CAPACITANCE	pF	16
10	SHUNT CAPACITANCE	Co	7.0pF
11	MOTIONAL CAPACITANCE	C1	NA
12	DRIVE LEVEL	mW	0.1mW
13	INSULATION RESISTANCE		> 500MΩ AT 100VDC
14	AGING/YEAR	PPM	<±3ppm

DIMENSION

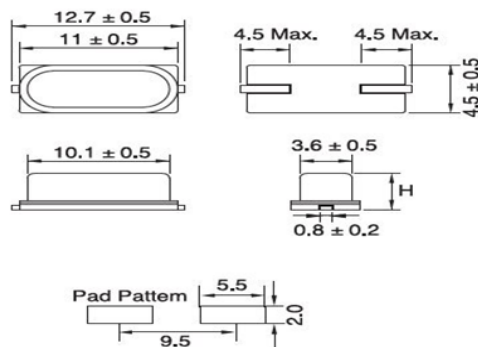

	H.MAX
49 M	4.2