



NIHON DEMPA KOGYO CO., LTD.

# APPROVAL SHEET

DATE: Jun 26, 2014

CUSTOMER :

PRODUCT NAME : Surface Mount Crystal Units

NDK Part Number

AT-41CD2-3.6864\_2030\_E\_N

This crystal is lead-free and RoHS compliant.



PREPARED BY : \_\_\_\_\_



CONFIRMED BY : \_\_\_\_\_

CUSTOMER APPROVAL :

CHECKED BY : \_\_\_\_\_

APPROVED BY : \_\_\_\_\_



## SPECIFICATION

**PACKAGE** : AT-41CD2

**NDK PART NO.** : AT-41CD2-3.6864\_2030\_E\_N

### ELECTRICAL CHARACTERISTICS :

1. **Nominal Frequency** : 3.686400MHz
2. **Oscillation Mode** : Fundamental
3. **Frequency Tolerance** :  $\pm 20$  ppm at 25°C
4. **Tolerance Stability over Temp. range** :  $\pm 30$  ppm at -40°C to +85°C
5. **Equivalent Series Resistance** : 150  $\Omega$  max.
6. **Load Capacitance** : 16 pF
7. **Operating Temperature Range** : -40°C to +85°C
8. **Drive Level** : 10  $\mu$ W typ., 100  $\mu$ W max.
9. **Storage Temperature Range** : -55°C to +125°C
10. **Aging** :  $\pm 5$  ppm max. / per year

**Date of specification : Jun 26, 2014**



NIHON DEMPA KOGYO CO., LTD.

## N-AT-41CD2-L12.4-07

### Dimension

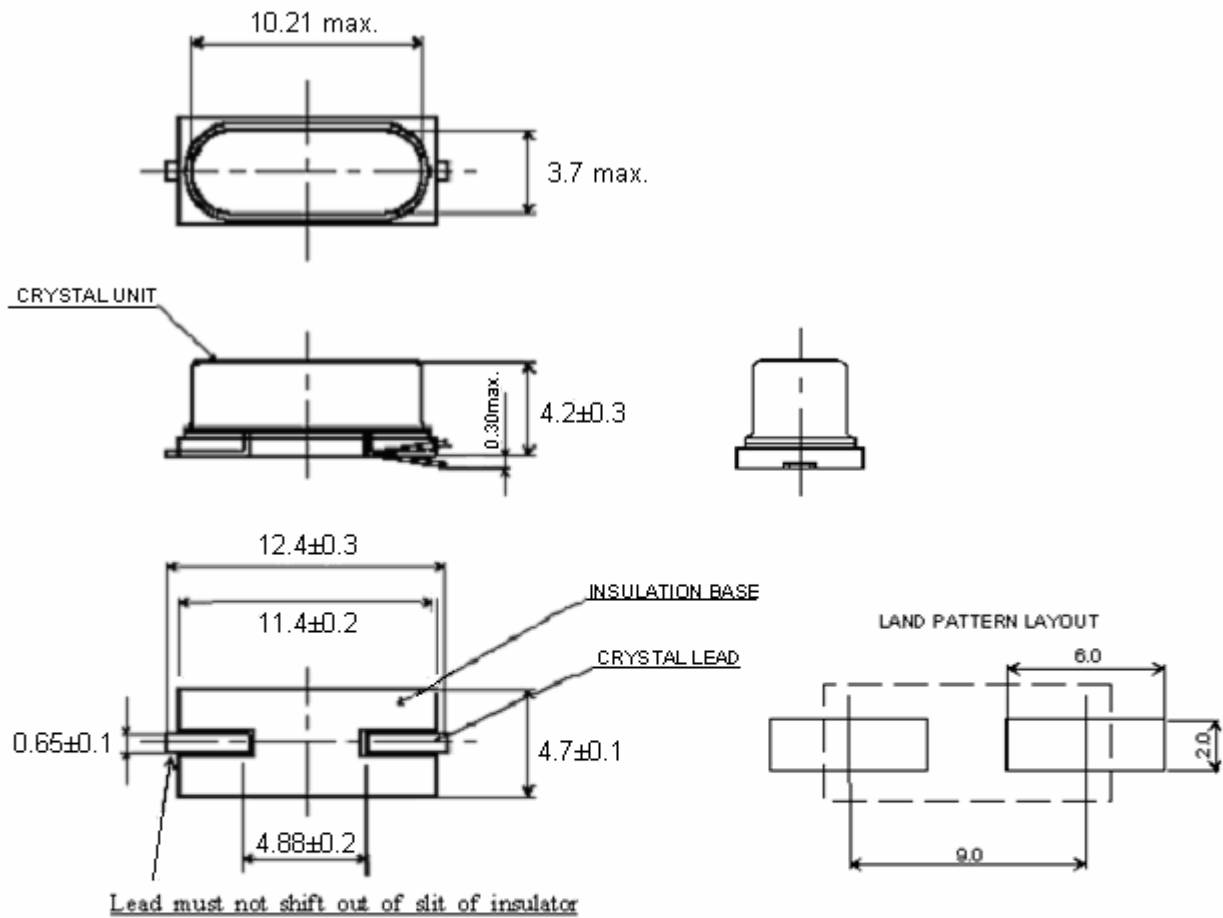

Unit : mm



NIHON DEMPA KOGYO CO., LTD.

## N-AT-41CD2-02

### Marking

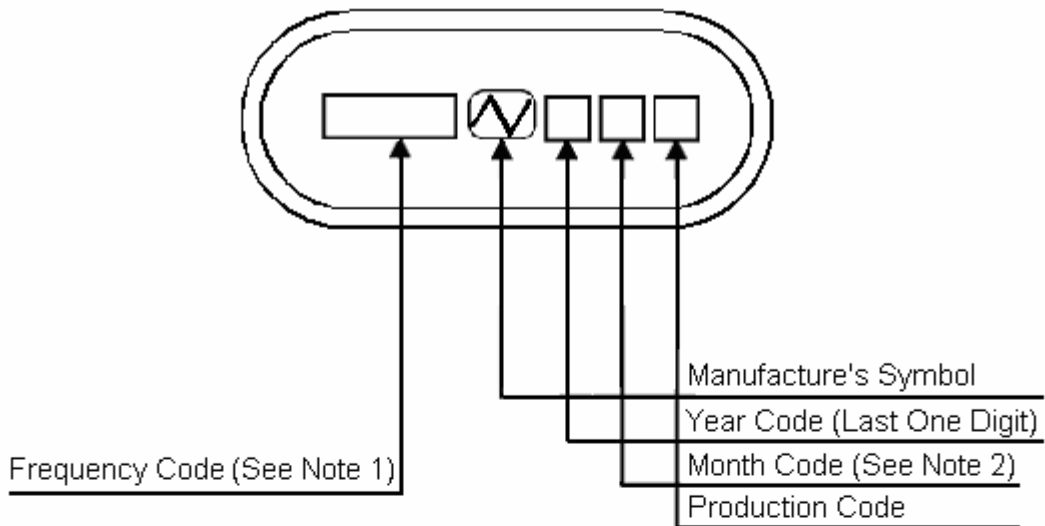

#### Note:

##### 1. Frequency Code

Frequency code is consisted of 3 digits, first 3 digits of nominal frequency.

Example

Frequency	4.194304MHz	4MHz
Frequency Code	4.19	4.00

##### 2. Month Code

Month	1	2	3	4	5	6	7	8	9	10	11	12
Month Code	1	2	3	4	5	6	7	8	9	X	Y	Z

Marking digits do not include a decimal point and dot mark.



NIHON DEMPA KOGYO CO., LTD.

## N-AT-41CD2-03

### Packaging

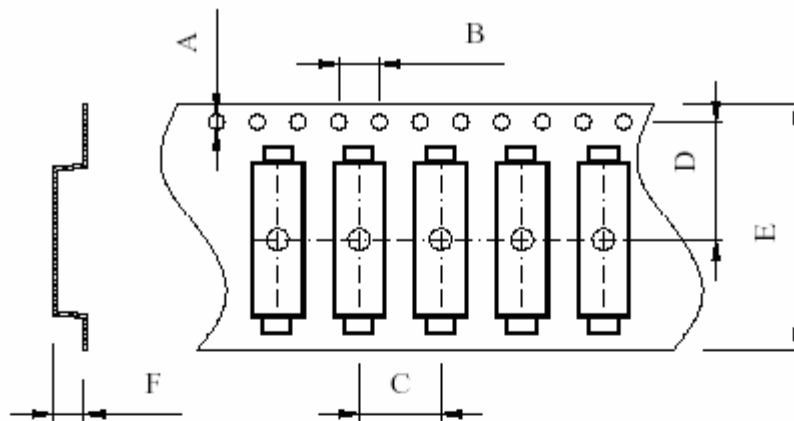

A	B	C	D	E	F
φ1.5	4.0	12.0	11.5	24.0	4.6

*Reel Dimensions(unit: mm)*

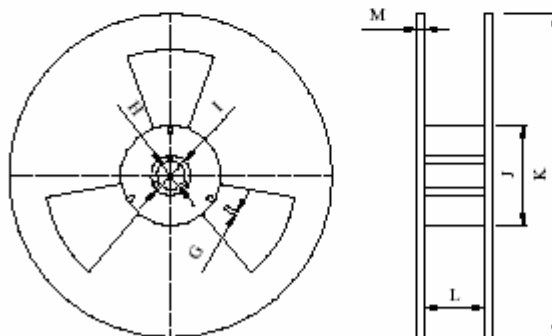

G	H	I	J	K	L	M
2.5	φ13.5	21.6	99.5	330	25.4	2.3

\*1000pcs/Reel



## N-AT-41CD2-02

### Guarantee Reliability Conditions

No	TEST ITEM	TEST METHODS	SPECIFICATION CODE
1	DROP	Device are dropped form the height 75cm onto wooden block (more than 3cm thickness) Execution 3 times random drops.	A
2	VIBRATION	Frequency : 10~55Hz Amplitude : 1.5mm Circuit : 1~2min Testing Period : 2h each direction	A
3	TERMINAL STRENGTH(1)Pull Test	A tensile force shall be applied to the termination in the direction of its draw-out axis gradually up to the specified value (10N), and maintained as it is for 10 s.	B
	TERMINAL STRENGTH(1)Bend Test	A weight of 0.45kg in mass is suspended from the end of termination. The body shall be turned through approx. 90 degrees per 2 to 3 s and then returned to the original position at the same rate.	B
4	SOLDERABILITY	235+/-5deg C, 5+/-0.5 s Dip	C
5	HEAT RESISTANCE OF SOLDERING	260+/-10deg C, 10 s max. Immersion	A
6	COLD RESISTANCE	-40+/-3deg C, 96 h	A
7	HUMIDITY	60deg C, 90~95%RH, 500h	A, D
8	THERMAL SHOCK	85+/-2deg C, -40+/-3deg C, each 30 min. 10 cycles	A
9	AGING	85+/-3deg C, 500h No operation	A

SPECIFICATION CODE	SPECIFICATION
A	(1) $\Delta f/f \leq \pm 5\text{ppm}$ (2) $\Delta C/C \leq 15\%$ or 2 ohm make use larger value
B	After testing unless cracking of materials view of eyes and unless break of seal, breaking of termination.
C	The leads shall acquire a new solder coat over at least 95% of immersed area.
D	Insulation resistance shall be greater than 500 M ohms.