

SPECIFICATION



NIHON DEMPA KOGYO CO.,LTD.

2014-10-22

Electrical characteristics

RoHS Compliant
Directive 2002/95/EC

	Item	Conditions	Specifications
2.1	Holder type	HC-49SM	AT-41CD2
2.2	Normal frequency		13.52915625MHz
2.3	Order of vibration		Fundamental
2.4	Adjustment tolerance	Reference temperature : 25+/-2°C	+/-50ppm
2.5	Frequency tolerance over temperature		+/-50ppm
2.6	Operating temperature range		-40°C--+85°C
2.7	Resonance resistance		<40 ohm
2.8	Load capacitance		16pF
2.9	Shunt capacitance	C0	< 7pF
2.10	motional capacitance	C1	NA
2.11	Spurious attenuation		>3dB
2.12	Drive level		1 mW
2.13	Insulation resistance		>500M ohm
2.14	Aging/year		<+/-3ppm

DIMENSION & LAND PATTERN

Marking & Dimension

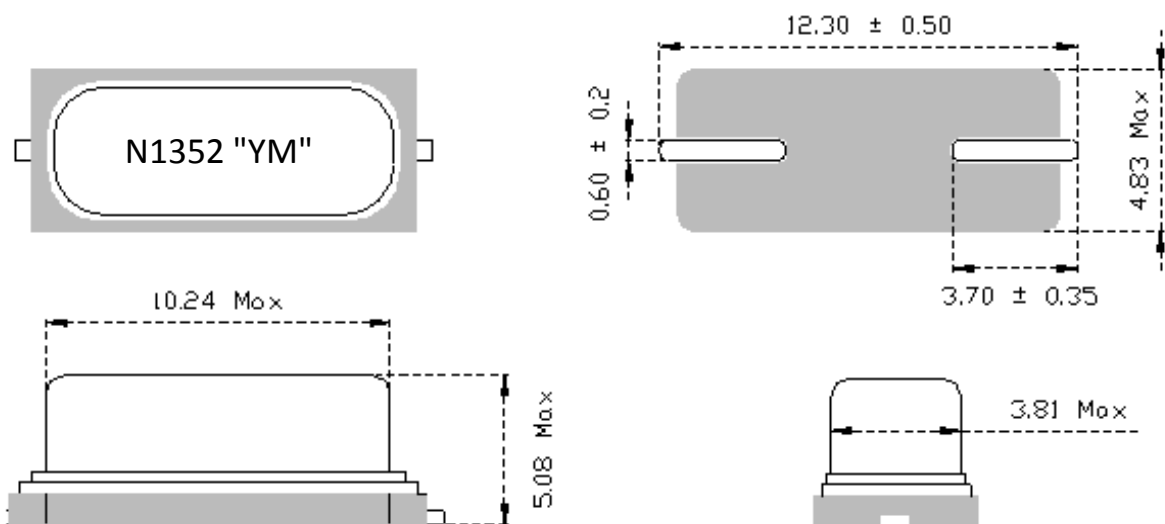

Marking -> YM (Y->Year, M->Month)
-> N (NDK)