

SPECIFICATION

Customer: ELTECH - INCOTEX

Item	CRYSTAL UNIT
Type	AT-41CD2
Customer's Spec. No.	
NDK Spec. No.	S1-4085-3030-18

Receipt

Charge:

Sales		Tel.		Drawn	<u>T. Kobayashi</u>
Engineer	Design Management Dept. Kobayashi	Tel.		Checked	_____
				Approved	<u>K. Shimazaki</u>

Applied Drawing

No.	Document Name	Doc. No.	No.	Document Name	Doc. No.
A					

-
1. Customer's Spec. No. :
2. NDK Spec. No. : S1-4085-3030-18
3. Type : AT-41CD2
4. Electrical Characteristics
- 4.1 Nominal Frequency (f₀) : 10.0000 MHz
- 4.2 Overtone Order : Fundamental
- 4.3 Adjustment Tolerance : $\pm 30 \times 10^{-6}$ max. (at 25°C)
- 4.4 Tolerance Over the Temperature Range : $\pm 30 \times 10^{-6}$ max. (at -40 to +85°C)
The reference temp. shall be 25°C
- 4.5 Equivalent Resistance (R_r) : 70Ω max.
- 4.6 Shunt Capacitance : 7.0pF max.
- 4.7 Insulation Resistance : Terminal to terminal Insulation resistance must be 500MΩ min. when DC 100V ±15V is applied.
5. Measurement Circuit
- 5.1 Frequency Measurement
- Measurement Circuit : CI meter (Saunders 150C)
- Load Capacitance (CL) : 18pF
- Level of Drive : 50μW
- 5.2 Resistance Measurement
- Measurement Circuit : CI meter (Saunders 150C)
- Load Capacitance (CL) : Series
- Level of Drive : 50μW
6. Other Characteristics
- 6.1 Seal Characteristics : 3×10^{-9} Pa·m³/s max.
Helium leak-detector
7. Data Sheet
Data sheets are not presented because above characteristics are guaranteed.
8. Notice
- (1) Order items are manufactured according to specification. As to conditions, which are not indicated in the specification and unpredictable such as applied condition and oscillation margin, please check them beforehand.
- (2) Unless we receive request for modification within 3 weeks from the issue date of this NDK Specification sheet, we will supply products according to the specification. Also, if you'd like to modify specification of order, which has been placed with delivery request within 3 weeks from the issue data of this specification sheet, we would like to discuss with you separately.
9. Applied Drawing
The applied drawing numbers are written in the cover of this specification.

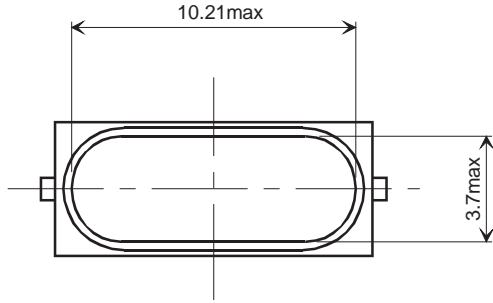

CRYSTAL UNIT

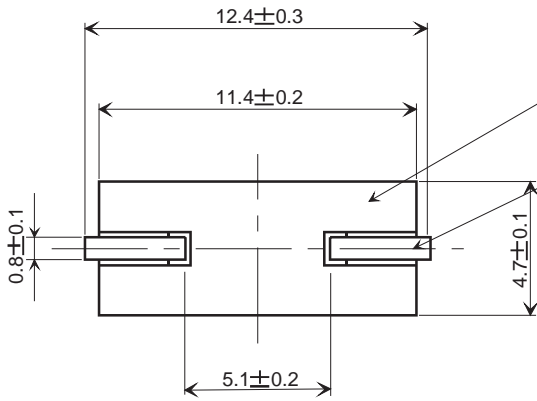
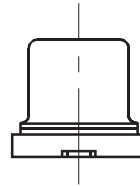
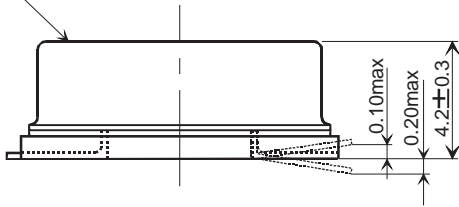

LAND PATTERN LAYOUT

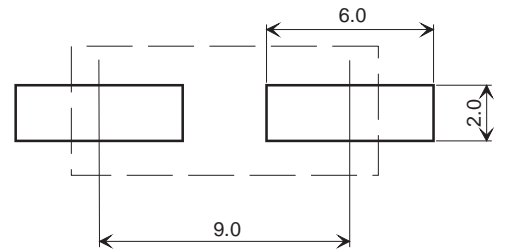

	Date of Revise	Charge	Approved	Reason		
B	20.Nov.2000	T.Kobayashi	K.Shimazaki	Remake with the new form by a form change.		
	Date	Name	Third Angle Projection	Tolerance	Scale	
Drawn	4.Feb.1999	K.Komada	Dimension:mm		3/1	
Designed	4.Feb.1999	T.Kubo	Title AT-41CD2 Dimension of External		Drawing No. EXD14B-00006	
Checked	4.Feb.1999	T.Shibata				Rev.
Approved	4.Feb.1999	T.Ishii				B

NIHON DEMPA KOGYO CO., LTD.

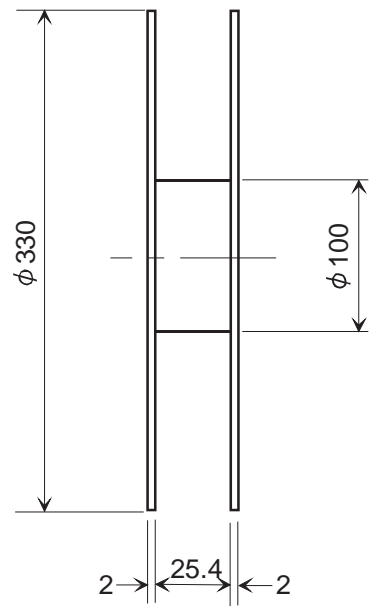
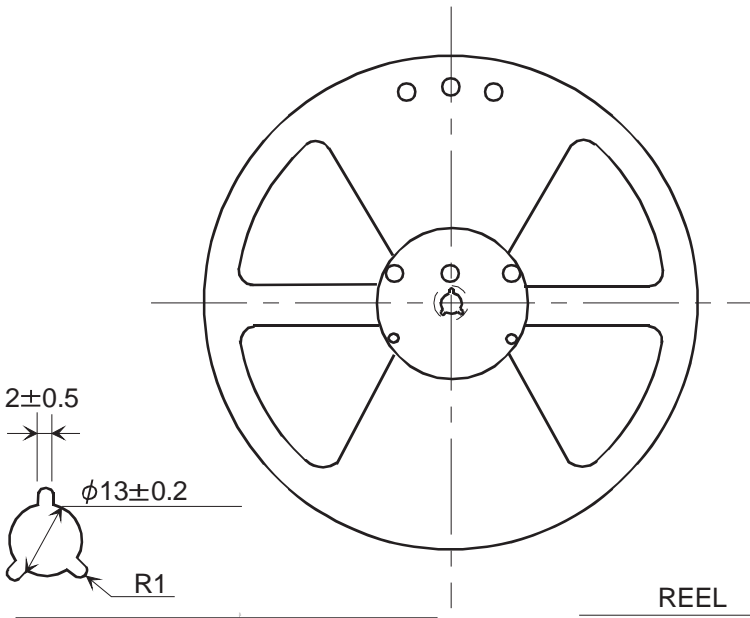
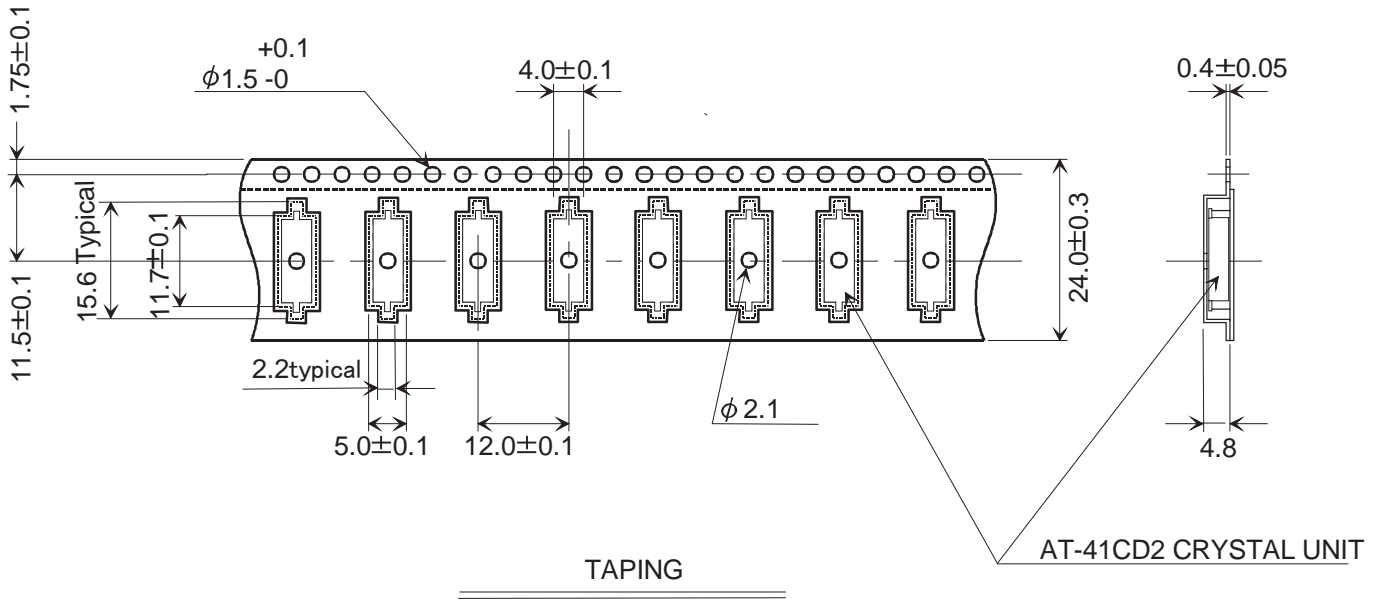

TAPING SYMBOL	QTY.
TPR58-R	1000 PCS

	Date of Revise	Charge	Approved	Reason		
B	24.Apr.2002	T.Kobayashi	K.Shimazaki	Attach Cavity diminution (2.2Typical)		
	Date	Name	Third Angle Projection	Tolerance		
Drawn	11.Nov.1999	N.Yamamoto	Dimension:mm	Scale		
Designed	11.Nov.1999	T.Kubo	Title	Drawing No.		
Checked	11.Nov.1999	A.Sagami			EXK17B-00043	Rev.
Approved	11.Nov.1999	T.Ishii				B
AT-41CD2 Taping and Reel Spec.						

NIHON DEMPA KOGYO CO., LTD.

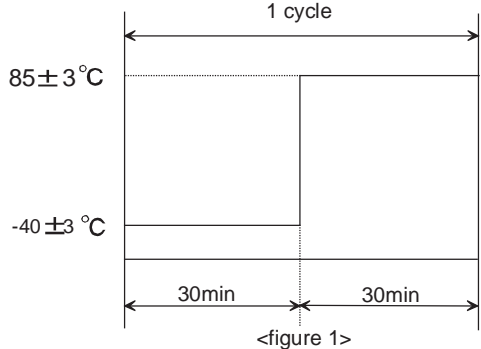
No.	Test Item	Test Methods	Specification Code
1	Shock	Device are dropped from the height 75 cm onto oak board.(more than 3 cm thickness) Execution 3 times random drops.	A
		Device are shocked to half sine wave (14700m/s ² , 0.5ms) 3 mutually perpendicular axes each 3 times.	A
2	Vibration	MIL-STD-202F Method 204D Condition D(196m/s ² peak)	A
3	Electrode Adherent Strength	See remark (1)	B
4	Humidity	Device are left in temperature at 60 °C with relative humidity of 90~95%RH for 500 h.	A,D
5	Thermal Shock	Device are left into the following temperature cycle as shown in <figure 1> for 10 consecutive cycle.  <figure 1>	A
6	Aging	Device are left in temperature at 85 ± 3°C for 500 h.	A
7	Solderability (Reflow)	Residual heat temperature: 150°C Residual heat time: 120s Peak temperature: 240°C (more than 200°C, 30s)	C
8	Resistance to soldering heat	Residual heat temperature: 150°C Residual heat time: 120s Temperature: 240°C Immersing time: 30s	A

Specification Code	Specification
A	$\Delta f/f \leq \pm 5\text{ppm}$ $\Delta CI \leq \pm 15\%$ or 5Ω make use larger value.
B	There are no exfoliation of the terminal electrode, crack and malfunctions of the others.
C	The leads shall acquire a new solder coat over at least 80% of immersed area.
D	Insulation resistance shall be greater than 500MΩ .

Remark(1) Electrode adherent strength

Test method and condition

Using the solder containing silver 2~3%, soldering iron or reflow soldering bath shall be used for soldering on test fixture(glass-epoxy board, FR-4, t=1.6mm)shown below.

