



FEATURES:

- RoHS compliant
- Wide 2:1 Input range
- Very low ripple and noise
- On/Off Control and Trim Function
- Regulated output
- High efficiency
- Operating temperature range: -40 to +85°C
- 1500VDC I/O Isolation

Models
Single output



Model	Input Voltage (V)	Output Voltage (V)	Output Current max (A)	Input Filter
AM50HB-2402S-UZ	18-36	2.5	10	π type
AM50HB-2403S-UZ	18-36	3.3	10	π type
AM50HB-2405S-UZ	18-36	5	10	π type
AM50HB-2412S-UZ	18-36	12	4.2	L type
AM50HB-2415S-UZ	18-36	15	3.2	L type
AM50HB-2424S-UZ	18-36	24	2.1	L type
AM50HB-2428S-UZ	18-36	28	1.8	L type
AM50HB-2448S-UZ	18-36	48	1.1	L type
AM50HB-4802S-UZ	36-72	2.5	10	π type
AM50HB-4803S-UZ	36-72	3.3	10	π type
AM50HB-4805S-UZ	36-72	5	10	π type
AM50HB-4812S-UZ	36-72	12	4.2	L type
AM50HB-4815S-UZ	36-72	15	3.2	L type
AM50HB-4824S-UZ	36-72	24	2.1	L type
AM50HB-4828S-UZ	36-72	28	1.8	L type
AM50HB-4848S-UZ	36-72	48	1.1	L type
AM50HB-11002S-UZ	66-160	2.5	10	π type
AM50HB-11003S-UZ	66-160	3.3	10	π type
AM50HB-11005S-UZ	66-160	5	10	π type
AM50HB-11012S-UZ	66-160	12	4.2	L type
AM50HB-11015S-UZ	66-160	15	3.2	L type
AM50HB-11024S-UZ	66-160	24	2.1	L type
AM50HB-11028S-UZ	66-160	28	1.8	L type
AM50HB-11048S-UZ	66-160	48	1.1	L type

Input Specifications

Parameters	Conditions	Typical	Maximum	Units
Voltage range		24, 18-36 48, 36-72 110, 66-160		VDC
Remote Control	CNTRL open CNTRL connect to -Vin	On Off	-0.7 ~ 0.4	V
Turn on time		10		ms
Start-up Delay Time		150		ms

Isolation Specifications

Parameters	Conditions	Typical	Maximum	Units
I/O Isolation voltage	Min	1500		VDC
Input / Case Isolation voltage	Min	500		VDC
Output / Case Isolation voltage	Min	500		VDC

Output Specifications

Parameters	Conditions	Typical	Maximum	Units
Set point accuracy			±1	%
Trim range		±10		%
Dynamic Response	200µs setting time	50-75% & 50-25% load	3% of Vout	Pk deviation
Short Circuit protection	Auto recovery	Continuous		
Over Temperature Protection	>105	110	115	°C
Total remote sense compensation		0.5		V
Line voltage regulation			±0.2	% of Vin
Load voltage regulation			±0.5	%
Temperature coefficient			±0.02	%/°C
Ripple & Noise			1	% of Vout

General Specifications

Parameters	Conditions	Typical	Maximum	Units
Switching frequency	100% load	330		KHz
Efficiency	At full load	87-90		%
Pin Solder Temperature	Wave solder <10s		250	°C
Hand Soldering time	Iron Temperature: 425 °C		5	sec
Operating temperature		-40 to +85		°C
Storage temperature		-55 to +125		°C
Case temperature		100		°C
Humidity		10 to 90		%
Weight	Without sink	75		g
Dimensions		2.28 x 2.4 x 0.5 inches	57.9 x 61 x 12.7 mm	
MTBF		>1,500,000 hrs (Bellcore TR332, t=+25°C)		

Safety Specifications

Standards	
Safety	EN60950

Pin Out Specifications

Pin	Single
1	-V Input
2	Case
3	On/Off Control
4	+V Input
5	+V Output
6	+Sense
7	Trim
8	-Sense
9	-V Output
10	Omitted

Dimensions

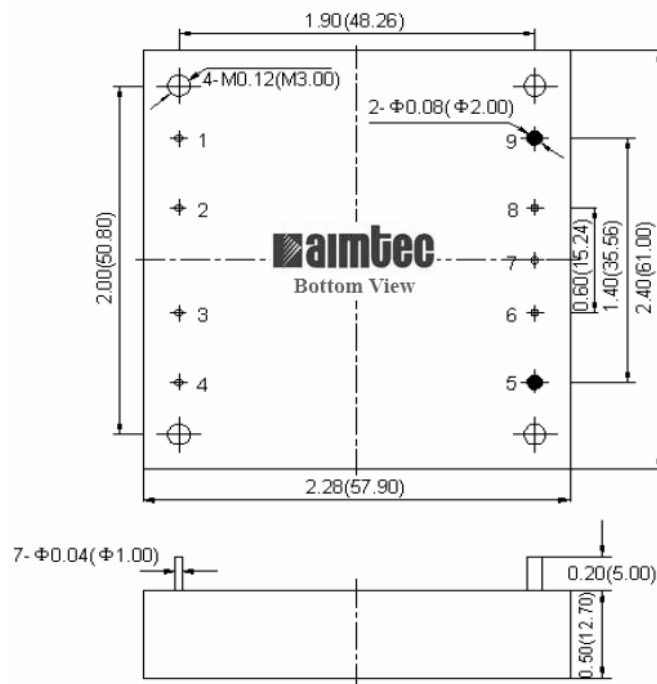

Derating:

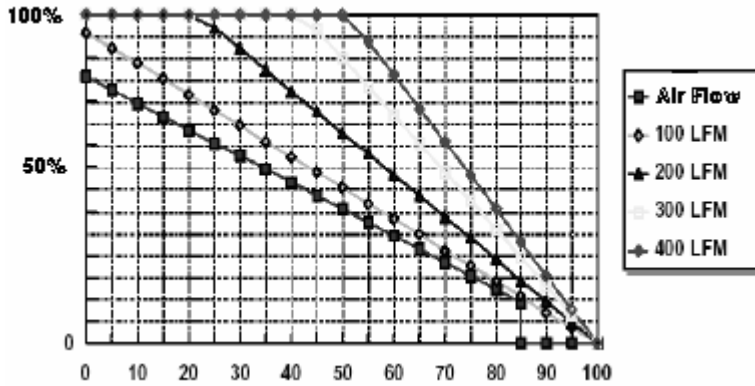

Typical Application:

Aimtec’s half brick models can operate independently. However, to enhance their performance and to ensure precision of the output signal parameters the following connections are recommended:

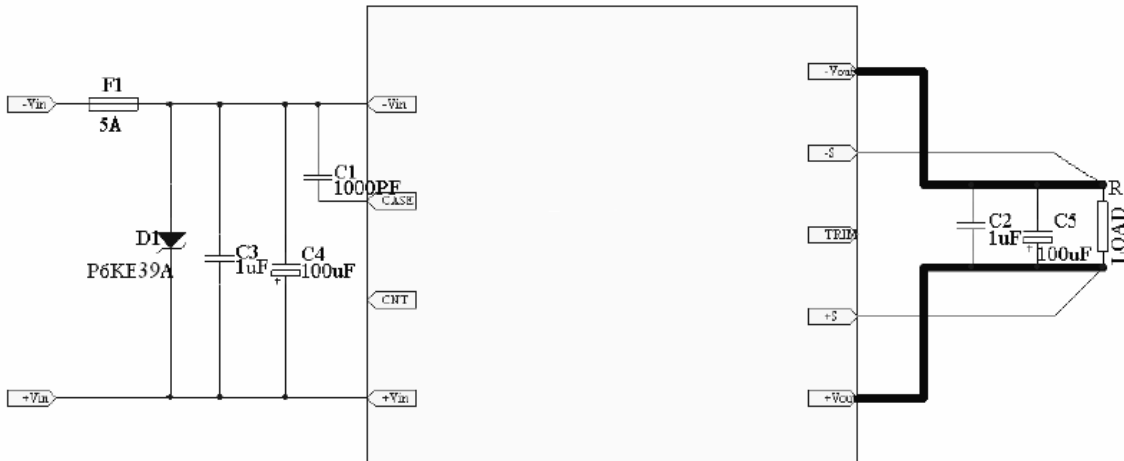

Output Ripple and Noise Measurement test setup:

Please refer to our Application note: **Ripple and Noise Measurement of Brick & POL DC-DC Converters.**

ON/OFF Control:

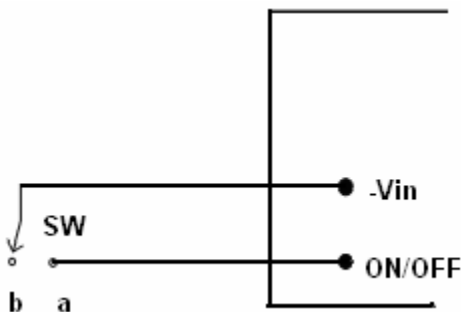

The converter output can be disabled by moving SW to position “a” – connected to $-V_{in}$ with voltage level between -0.7 and 0.4V.

When SW is open “in position b”, the converter is ON and operates normally.

The SW can be replaced by a NPN transistor with connection as follows:

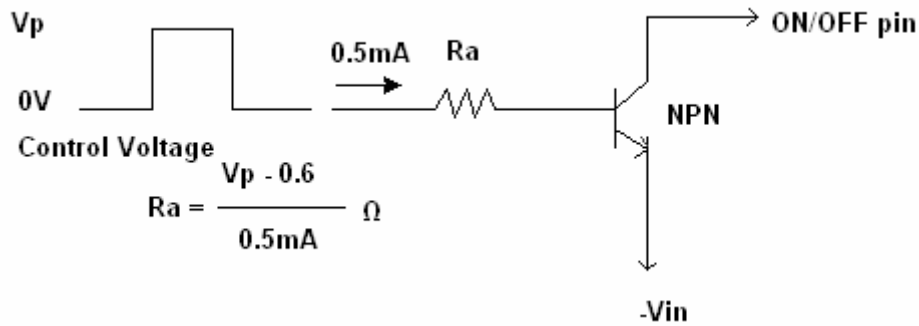

Output Voltage Trim connection:

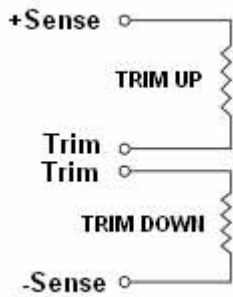

The output voltage can be adjusted by connecting trim resistors as shown.

The values can be determined according to the following formulas where $\Delta\%$ is the desirable voltage adjustment in percentage and V_o is the Nominal value of the Output Voltage:

$$R_{up} = \left[\frac{V_o(100+\Delta\%) - (100+2\Delta\%)}{1.225\Delta\%} - \frac{(100+2\Delta\%)}{\Delta\%} \right] K\Omega$$

$$R_{down} = \left[\frac{100 - 2}{\Delta\%} \right] K\Omega$$

The calculated Resistor values are in K Ω .