

未注公差/General tolerances(mm)													
0	>3	>6	>10	>18	>30	>50	>80	>120	>180	>250	>315	>400	
~3	~6	~10	~18	~30	~50	~80	~120	~180	~250	~315	~400	>500	
±0.12	±0.18	±0.22	±0.26	±0.31	±0.37	±0.57	±0.80	±0.93	±1.05	±1.15	±1.60	±2.20	±2.50

A
B
C
D

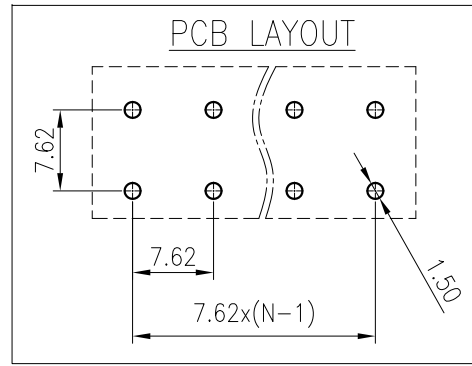
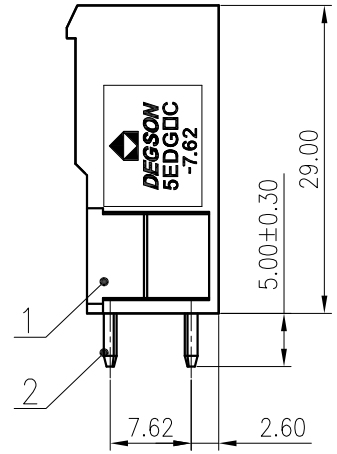
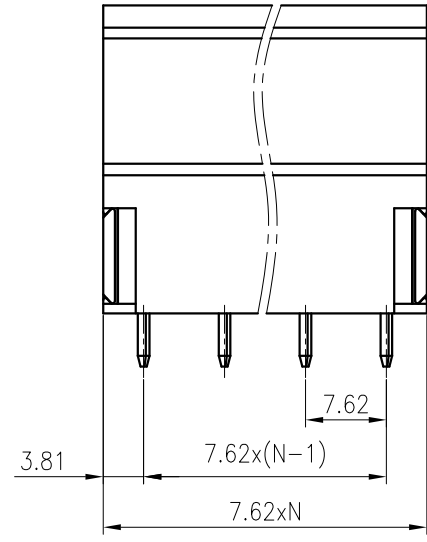
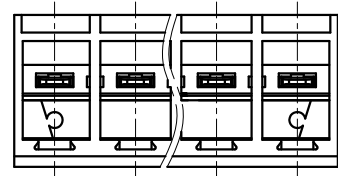
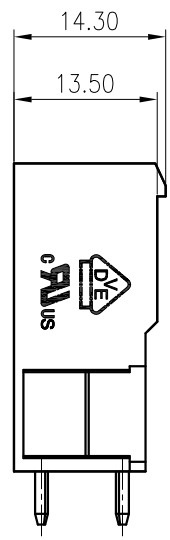

2	Pin	Copper	Sn Plated
1	Housing	PBT	UL94V-0
ITEM	NAME OF PART	MATERIAL	NOTES
UL 标准/UL Standard:		B	C
额定电压/电流/Rated Voltage(V)/Current(A)		300/30	300/30
EC 标准/IEC Standard:		D	
过压类别/Overvoltage Category/污染等级/Pollution Degree		III/3	III/2
额定电压/电流/Rated Voltage(V)/Current(A)		/	400/32
额定脉冲电压(KV)/Rate Impulse Voltage(KV)		/	4
间距/Pitch(mm)/线数范围/Poles		7.62/N=02~12P	
使用温度范围/Operating temperature(°C)		-40~+105	
符合RoHS环保要求/Conform to RoHS		Yes	

MATERIAL:	SURFACE:		
MAT NO.:	/		
STATUS:	/		
APPD:	NAME:		
CHKD:	5EDGVC-7.62-XXP-1Y-00A(H)		
DRFT: CenMZ 2020.06.05	DRAWING NO.: 5EDGVC-7.62-C01	REV	TO
⊕	SIZE: A4	SCALE: 1.5:1	SHEET 1/1

REV	ECN	DESCRIPTION	DRFT	DATE