

REVISION RECORD

REV	ECN	DESCRIPTION	DRFT	DATE
-----	-----	-------------	------	------

NOTES1:

UL Standard

- 1.Rated voltage/current : 300V / 30A
- 2.Withstanding voltage : AC1600V/1Min.
- 3.Torque value : M3 , 4.43Lb.in
- 4.Wire range : 28~10AWG

IEC Standard

1. Pollution degree	2
Overvoltage category	III
Rate impulse voltage(KV)	4.0KV
Rate voltage(V)	400V
Rate current(A)	32A

- 2.Torque value : M3 , 0.5N·m
- 3.Wire range : 0.2~4mm<sup>2</sup>

NOTES2:

- 1.Dimension shall be interpreted per ASME Y14.5-2009
- 2.Pitch : 7.62mm, Poles : N=02~12P
- 3.Stripping length : 7mm
- 4.Operating temperature: -40°C~+105°C
- 5.Undimensioned tolerances:

Pitch range in mm		Nominal dimension range in mm						
TO	Over	Over	TO	Over	Over	Over	0.1/10	
6	6 TO 10	10 TO 24	30	30 TO 60	60 TO 100	100 TO 150	≤	
±0.15	±0.20	±0.30	±0.30	±0.50	±0.70	±1.00	±2'	

6.RoHS Compliance

5EDGK - 7.62 - XXP - 1Y - 00A (H)  
 (Series No.) (Poles) (Single Pitch) (Color):1.(Grey)  
 2.(Blue)  
 3.(Black)  
 4.(Green)  
 5.(Orange)  
 6.(Red)  
 7.(Transparent)  
 8.(Yellow)  
 9.(White)

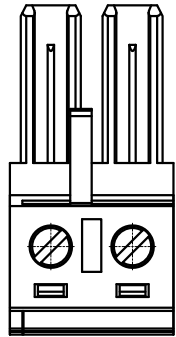

2P

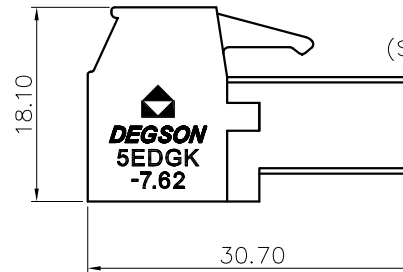
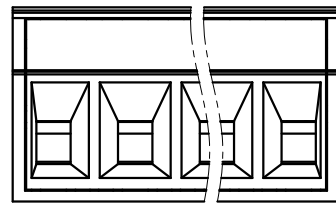
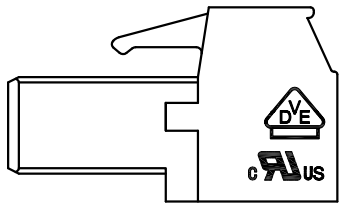
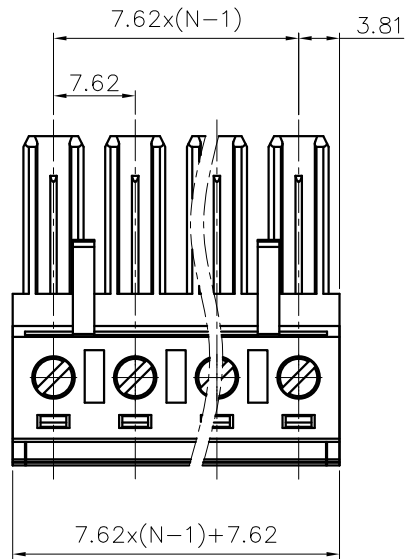

DETACHED LISTS	PART NO.:	NINGBO DEGSON ELECTRICAL CO., LTD			
	APPD:	NAME: 5EDGK-7.62-XXP-1Y-00A(H)			
	CHKD:	TITLE: CUSTOMER DRAWING			
	DRFT:	DRAWING NO.:		REV	DO
	THIRD ANGLE PROJECTION		MM (INCH)	DO NOT SCALE DRAWING	SCALE 1:1