

NOTES 1:

UL Standard :

1. Rating: 300V 15A
2. Insulation Withstands Voltage: AC 2000V at 1 minute
3. Using Temperature Range: -40°C~+115°C
4. Screw Torque Value: 0.5N·m
5. Suitable Electric Wire: AWG 28~12(Sol)
30~12(Str)

IEC Standard:

1. Rating: 800V 18A
2. Rate Impulse Voltage: 6000V
3. Insulation Resistance: 500MΩ or more at DC500V
4. Material Group : I
5. Pollution Degree : 2
6. Overvoltage Category: II
7. Using Temperature Range: -40°C~+110°C
8. Screw Torque Value: 0.4N·m
9. Suitable Electric Wire: 0.2~2.5mm²

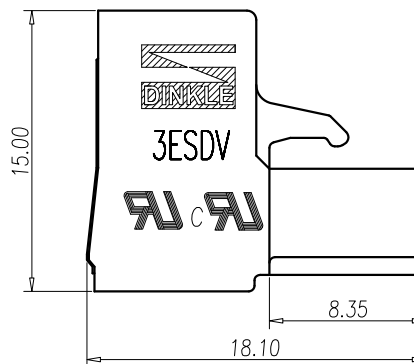
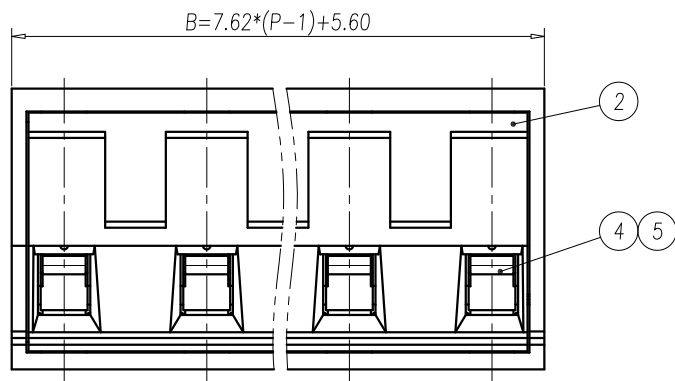

NOTES 2:

1. RoHS compliance
2. Strip Length: 7~8mm

P	2	3	4	5	6	7	8	9	10	11	12
A	7.62	15.24	22.86	30.48	38.10	45.72	53.34	60.96	68.58	76.20	83.82
B	13.22	20.84	28.46	36.08	43.70	51.32	58.94	66.56	74.18	81.80	89.42

5	CLAMP	COPPER ALLOY	Tin Plated
4	WIRE CAGE	STEEL	M2.5/Zn Plated
3	SCREW	STEEL	M2.5/Zn Plated
2	COVER	PA66	UL94-V0 BLUE
1	HOUSING	PA66	UL94-V0 BLUE
ITEM	NAME OF PART	MATERIAL	NOTES

Total Pitch Tolerances		Normal Dimension Tolerances	
0~30	±0.20	0~30	±0.25
over 30~53	±0.25	over 30~53	±0.30
over 53~70	±0.30	over 53~70	±0.35
over 70~90	±0.35	over 70~90	±0.44
over 90~115	±0.44	over 90~115	±0.55
over 115~150	±0.55	over 115~150	±0.70
over 150~200	±0.70	over 150~200	±0.85
over 200~250	±0.85	over 200~250	±1.00
over 250~320	±1.00	over 250~320	±1.20

△			
REV.	CONTENT	NAME	DATE

DWG.	ZCT	DATE	2021.11.18	UNITS	MM	SHEET/OF	1 / 1
CHK.	Ying.Xu	DATE	2021.11.18	SCALE	3.5:1 (:)		
APP.	Webb.Liu	DATE	2021.11.18	NAME	3ESDV-XXP-BL		
DINKLE ENTERPRISE CO., LTD.				DWG NO.	SP-03-3ESDV0BL		