

2EEHDVC-XXP

PCB Terminal blocks > PCB Connector-Socket

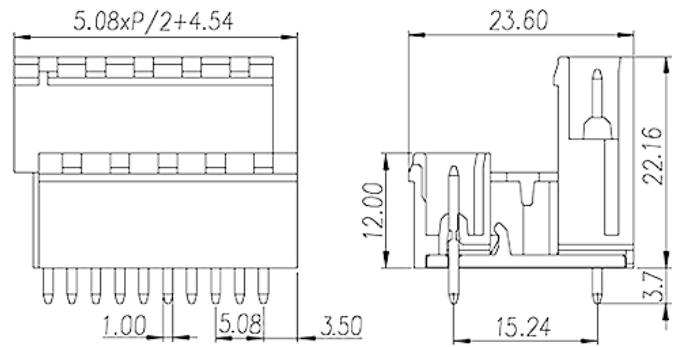

Product Description

Pitch: 5.08 mm , 300V, 15A

General information

Short description	PCB connector socket , Wave soldering
Soldering method	Wave soldering
Type of locking	Without
Pitch mm	5.08
Level	Double level
Pin demensions (Thickness x Width) mm	1.0X1.0
PCB hole diameter mm	1.6~1.7

Material information

Insulation material	PA66
Flame retardant rating , compliant with UL94	V0
Color	Green
Conductor material	Copper Alloy
Plating of conductor surface	Tinned

Connection data-UL

Rated voltage V (UL/CUL standard group B)	300
---	-----

Rated current A (UL/CUL standard group B)	15
Rated voltage V (UL/CUL standard group D)	300
Rated current A (UL/CUL standard group D)	10

Connection data-IEC

Rated data	IEC 61984
Surge voltage category	II
Pollution degree	2
Insulating material group	I
Rated current A	18
Rated voltage V	600
Rated voltage V (II/2)	600
Rated voltage V (III/2)	320
Rated voltage V (III/3)	250
Rated impulse voltage KV (II/2)	4
Rated impulse voltage KV (III/2)	4
Rated impulse voltage KV (III/3)	4

Environment & Safety

Finger protection (YES or NO)	YES
Operating temperature. max °C	115
Operating temperature. min °C	-40

Drawings

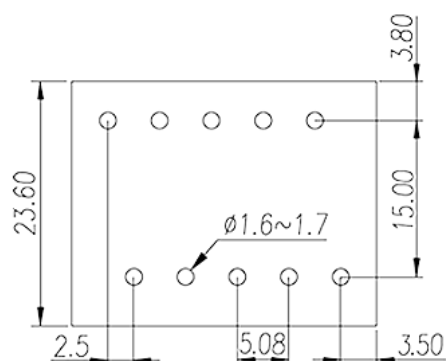
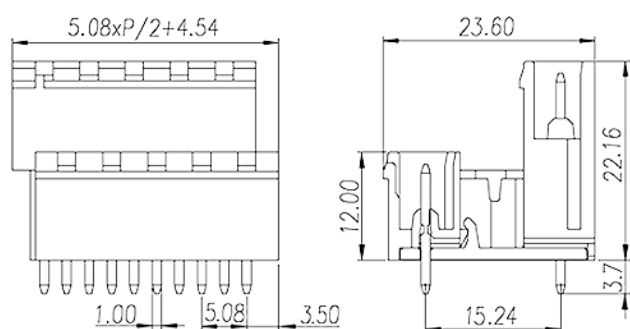

Accessories

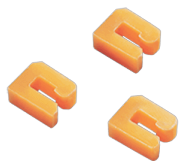

EHDK1

For EHD series Orange color Using UL94-V0 class of insulation material

Approvals

