

REVISION RECORD				
REV	ECN	DESCRIPTION	DRFT	DATE

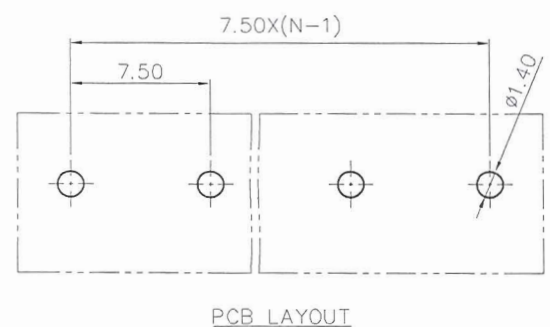
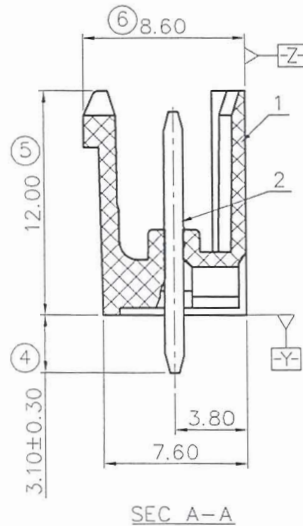
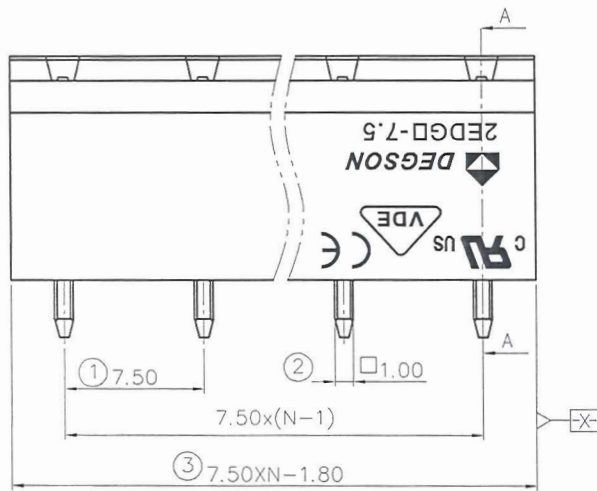
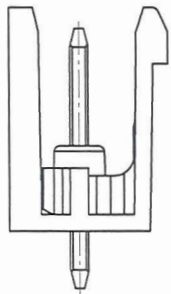
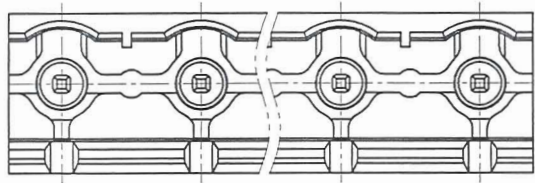

备注一:
UL 标准
1. 额定电压与电流 : 300V /15A
2. 工频耐压 : AC1600V/1Min.

VDE 标准

1.

污染等级	2
过压类别	III
额定脉冲电压(KV)	4.0KV
额定电压(V)	400V
额定电流(A)	20A

备注二:
1. 尺寸标注符合标准 ASME Y14.5-2009
2. P距 : 7.5mm, P数范围 : N=02~12P
3. 使用温度范围 : -40°C~+105°C
4. 顶出力 ≥25N
5. "⊗" 为重点管控尺寸
6. 未注公差表:

P距方向公差(mm)		其他尺寸公差(mm)				—	∩	∇
≤6	6 ~ 10	10 ~ 24	≤30	30 ~ 60	60 ~ 100	100 ~ 150	>150	0.05/10
±0.10	±0.15	±0.25	±0.20	±0.30	±0.50	±0.70	±1.00	±1'

7. 变形度管控:
02P: 0.85/100 、 03P-08P: 0.75/100,
09P-10P: 0.7/100 、 11P-12P: 0.6/100
(注: 如02P变形度0.85/100, 表示对应产品线数总长乘以0.0085计算得出的数据是产品的变形度。)
8. 须符合RoHS环保要求

文管中心
研发专用
2015.12.17
 (仅限内部使用,对外无效)

2	2EDGVC-13A-针	1007B00190(H)	N	紫铜	镀锡
1	2EDGV/R-7.5-100A-塑件	1026AYYXXA(H)	1	PA66	UL94V-0
ITEM	NAME OF PART	NO. OF PART	Q"TY	MATERIAL	NOTES
PART NO.:		NINGBO DEGSON ELECTRICAL CO., LTD			
APPD: Aaron 12/15/15		NAME: 2EDGV-7.5-XXP-1Y-100A(H)			
CHKD: Xlm 12/15/15		TITLE: ASSEMBLY DRAWING			
DRFT: HHJ 01/27/15"		REV		TO	
DRAWING NO.: 2EDGV-7.5-E01		SHEET		1/1	
THIRD ANGLE PROJECTION		DO NOT SCALE DRAWING		SCALE 1:1	

REVISION RECORD

REV	ECN	DESCRIPTION	DRFT	DATE
-----	-----	-------------	------	------

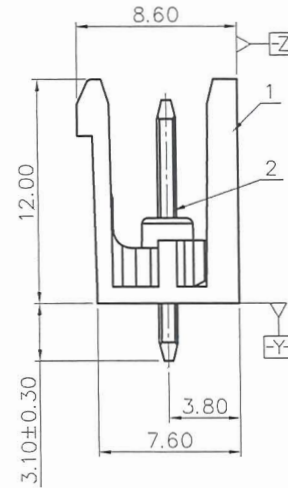
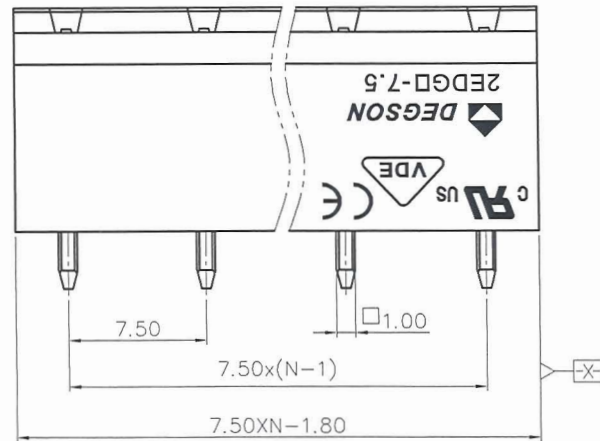
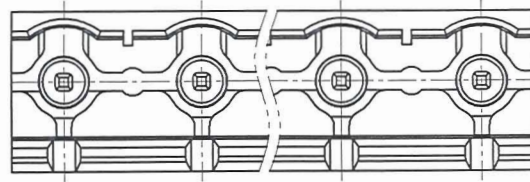

NOTES1:

UL Standard

1. Rated Voltage/Current : 300V / 15A
2. Withstanding Voltage : AC1600V/1Min.

IEC Standard

1. Pollution Degree	2
Overvoltage Category	III
Rate Impulse Voltage(KV)	4.0KV
Rate Voltage(V)	400V
Rate Current(A)	20A

NOTES2:

1. Dimension shall be interpreted per ASME Y14.5-2009
2. Pitch : 7.5mm, Poles : N=02~12P
3. Operating temperature: -40°C~+105°C
4. Undimensioned Tolerances:

Pitch Range In mm		Nominal Dimension Range In mm				-	∧	∇
TO 6	Over 6 TO 10	Over 10 TO 24	Over 30 TO 60	Over 60 TO 100	Over 100 TO 150	0.1/10	<	
±0.15	±0.20	±0.30	±0.30	±0.50	±0.70	±1.00	±1.30	±2*

5. RoHS Compliance

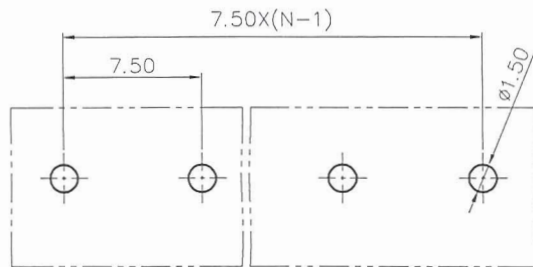

PCB LAYOUT

文管中心
研发专用
2015.12.17
(仅限内部使用,对外无效)

2	PIN	COPPER ALLOY	SN PLATED
1	HOUSING	PA66	UL94V-0
ITEM	NAME OF PART	MATERIAL	NOTES

PART NO.:		宁波高松电子有限公司	
APPD: Aaron 12/10/15		DEGSON® NINGBO DEGSON ELECTRICAL CO., LTD	
CHKD: 7/12/15		NAME: 2EDGV-7.5-XXP-1Y-100A(H)	
DRFT: HHJ 07/27/15"		TITLE: CUSTOMER DRAWING	
THIRD ANGLE PROJECTION		DRAWING NO.: 2EDGV-7.5-C01	REV TO
		MM (INCH)	SHEET 1/1
		DO NOT SCALE DRAWING	SCALE 1:1