

未注公差/General tolerances(mm)											0.1/10 ±2'		
0 ~ 3	>3 ~ 6	>6 ~ 10	>10 ~ 18	>18 ~ 30	>30 ~ 50	>50 ~ 80	>80 ~ 120	>120 ~ 180	>180 ~ 250	>250 ~ 315		>315 ~ 400	>400 ~ 500
±0.12	±0.18	±0.22	±0.26	±0.31	±0.37	±0.57	±0.80	±0.93	±1.05	±1.15	±1.60	±2.20	±2.50

A

2P:Clasp on the left from this view

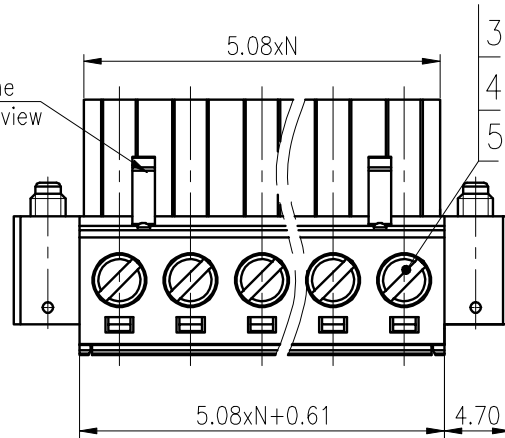

B

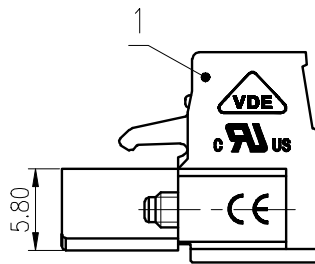

C

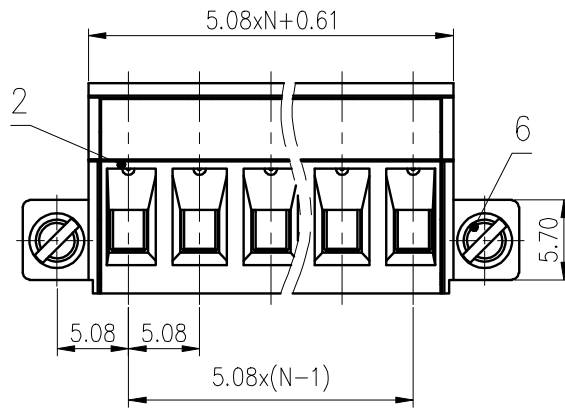

D

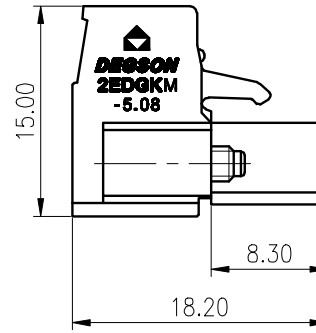

6	Screw2	Steel	M2.5/Zn Plated
5	Clamp	Copper alloy	Sn Plated
4	Cage	Copper alloy	Ni Plated
3	Screw1	Steel	M3/Zn Plated
2	Cover	PA66	UL94V-0
1	Housing	PA66	UL94V-0

ITEM	NAME OF PART	MATERIAL	NOTES
UL 标准/UL Standard:		B	C D
额定电压/电流/Rated Voltage(V)/Current(A)		300/15	/ 300/10
IEC 标准/IEC Standard:			
过压类别/Overvoltage Category/污染等级/Pollution Degree		III/3	III/2 II/2
额定电压/电流/Rated Voltage(V)/Current(A)		/	320/20 /
额定脉冲电压(kV)/Rate Impulse Voltage(kV)		/	4 /
螺丝扭矩/Torque Tightening(N·m)		M3, 0.58	
线径范围(硬线和软线)/Wire Range(rigid and flexible)(mm ² /AWG)		1.0~2.5/28~12	
间距/Pitch(mm)/线数范围/Poles		5.08/N=02~22P	
剥线长度/Stripping length(mm)		7~8	
使用温度范围/Operating temperature(°C)		-40~+105	
符合RoHS环保要求/Conform to RoHS		Yes	

MATERIAL: /	SURFACE: /		
MAT NO.: /	宁波高松电子有限公司 NINGBO DEGSON ELECTRICAL CO., LTD		
STATUS: /			
APPD: LanChH 2020.005.26	NAME: 2EDGKM-5.08-XXP-1Y-1000A(H)		
CHKD: GongYZh 2020.05.26	DRAWING NO.: 2EDGKM-5.08-C36		
DRFT: FRZ 2015.11.16	REV	T1	
SIZE: A4 TYPE: CUSTOMER DRAWING SCALE: 2:1 SHEET 1/1			

REV	ECN	DESCRIPTION	DRFT	DATE

1

2

3

4

5

6