

REVISION RECORD				
REV	ECN	DESCRIPTION	DRFT	DATE

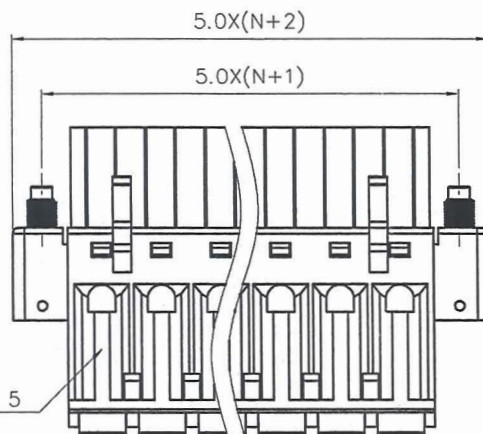
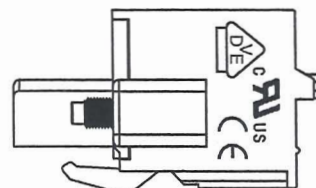
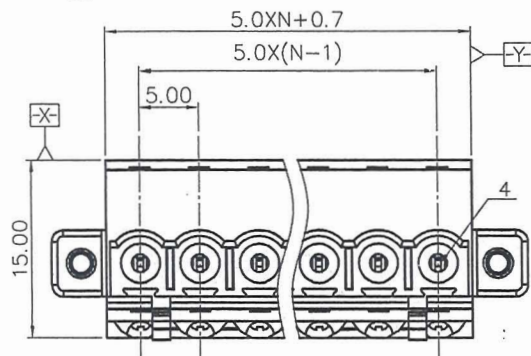
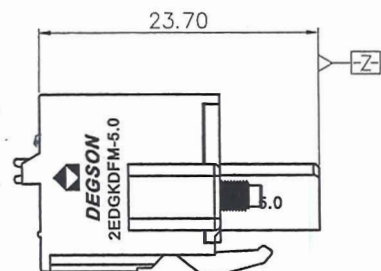
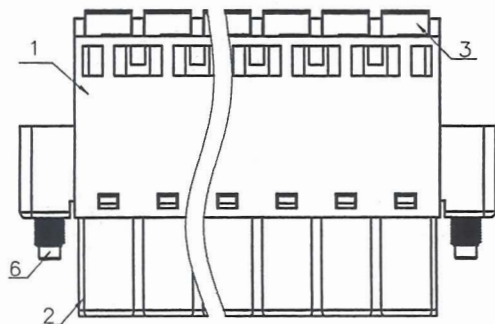
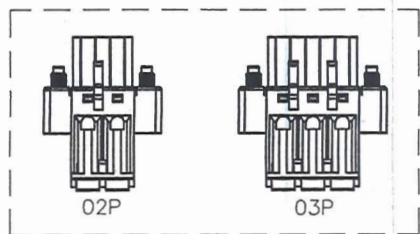

NOTES1:

UL Standard

- Rated Voltage/Current : 300V / 10A
- Withstanding Voltage : AC1600V/1Min.
- Wire Range : 26~12AWG

IEC Standard

1. Pollution Degree	2
Overvoltage Category	III
Rate Impulse Voltage(KV)	4.0KV
Rate Voltage(V)	320V
Rate Current(A)	20A

2. Wire Range : 0.2~2.5mm<sup>2</sup>

NOTES2:

- Dimension shall be interpreted per ASME Y14.5-2009
- Pitch : 5.0mm, Poles : N=02~22P
- Stripping length : 9-10mm
- Operating temperature : -40°C~+105°C
- Undimensioned Tolerances:

Pitch Range In mm	Nominal Dimension Range In mm						0.1/10		
	Over 6 TO 6	Over 10 TO 10	Over 10 TO 24	Over 30 TO 30	Over 60 TO 60	Over 100 TO 150			
	±0.15	±0.20	±0.30	±0.30	±0.50	±0.70	±1.00	±1.30	±2*

6. RoHS Compliance

文管中心  
研发专用  
2015.10.31  
(仅限内部使用,对外无效)

ITEM	NAME OF PART	MATERIAL	NOTES
6	Screw	STEEL	Zn plated
5	Spring	STAINLESS STEEL	
4	Clamp	COPPER ALLOY	Sn Plated
3	Button	PA66	UL94-V0
2	Cover	PA66	UL94-V0
1	HOUSING	PA66	UL94-V0

PART NO:		宁波高松电子有限公司 NINGBO DEGSON ELECTRICAL CO., LTD	
APPD: Aaron 10/18/15	NAME:	2EDGKDFM-5.0-XXP-1Y-00A(H)	
CHKD: Xminid/15	TITLE: CUSTOMER DRAWING	REV	TO
DRFT: LZT 01/03/13"	DRAWING NO.: 2EDGKDFM-5.0-C01	SHEET	1/1
THIRD ANGLE PROJECTION		DO NOT SCALE DRAWING	SCALE 1:1