

未注公差/General tolerances(mm)											0.1/10 ±2°		
0 ~ 3	>3 ~ 6	>6 ~ 10	>10 ~ 18	>18 ~ 30	>30 ~ 50	>50 ~ 80	>80 ~ 120	>120 ~ 180	>180 ~ 250	>250 ~ 315		>315 ~ 400	>400 ~ 500
±0.12	±0.18	±0.22	±0.26	±0.31	±0.37	±0.57	±0.80	±0.93	±1.05	±1.15	±1.60	±2.20	±2.50

View A

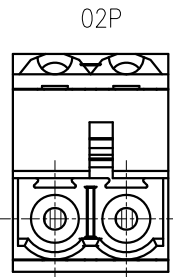
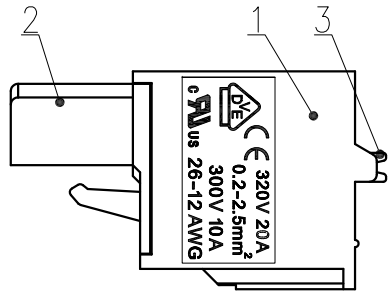
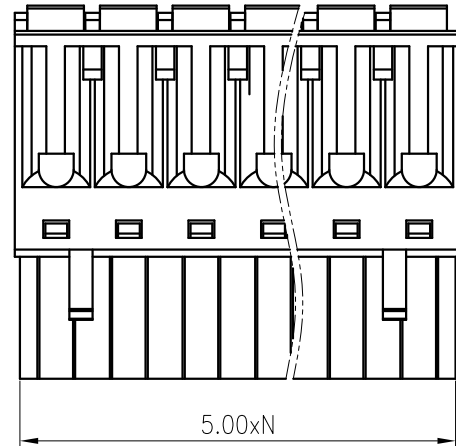
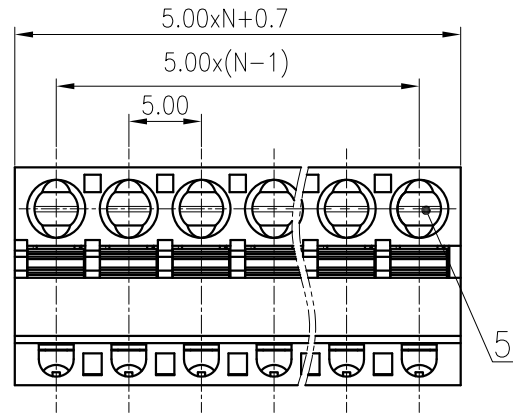
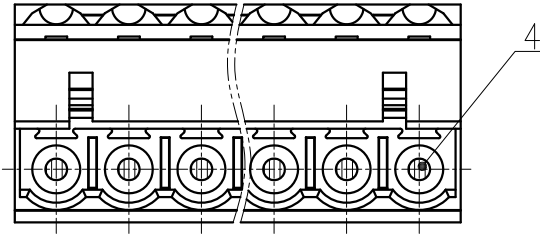

5	Spring	Stainless steel	/
4	Clamp	Copper alloy	Sn Plated
3	Button	PA66	UL94V-0
2	Cover	PA66	UL94V-0
1	Housing	PA66	UL94V-0

ITEM	NAME OF PART	MATERIAL	NOTES
UL 标准/UL Standard:		B	C
额定电压/电流/Rated Voltage(V)/Current(A)		300/10	/ 300/10
EC 标准/IEC Standard:			
过压类别/Overvoltage Category/污染等级/Pollution Degree		III/3	III/2 11/2
额定电压/电流/Rated Voltage(V)/Current(A)		/	320/20 /
额定脉冲电压(KV)/Rate Impulse Voltage(KV)		/	4 /
线径范围(硬线和软线)/Wire Range(rigid and flexible)(mm ² /AWG)		0.2~2.5/26~12	
间距/Pitch(mm)/线数范围/Poles		5.0/N=02~24P	
剥线长度/Stripping length(mm)		9-10	
使用温度范围/Operating temperature(°C)		-40~+105	
符合RoHS环保要求/Conform to RoHS		Yes	

MATERIAL: /		SURFACE: /	
MAT NO.: /	宁波高松电子有限公司 NINGBO DEGSON ELECTRICAL CO., LTD NAME: 2EDGKD-5.0-XXP-1Y-00A(H)		
STATUS: /			
APPD: Li GL 2020.05.26			
CHKD: Ma EK 2020.05.26			
DRFT: Apple 2006.10.20	DRAWING NO.: 2EDGKD-5.0-C01	REV	T1

REV	ECN	DESCRIPTION	DRFT	DATE	SIZE: A4	TYPE: CUSTOMER DRAWING	SCALE: 2:1	SHEET	1/1
-----	-----	-------------	------	------	----------	------------------------	------------	-------	-----