



SPECIFICATION

Customer: ELTECH

Item:	Crystal Clock Oscillators
Type:	2725T
Nominal Frequency:	12MHZ
Customer's Spec. No.:	-----
NDK Spec. No.:	40/85 -50PPM-3.3VCMOS

Receipt

Charge:

--	--	--	--	--

1.Type

2725T

2.NDK Spec. No.

40/85-50PPM-3.3V CMOS

3.Maximum Ratings

3.1 Supply Voltage(V_{DD})

-0.5 ~ +7.0 V DC

3.2 Storage Temp.

-55 ~ +125 °C

4.Operating Temp. Range

-40 ~85 °C

5. Performance

5.1 Output Frequency

12MHz

5.2 Standard Supply Voltage(V_{DD})+3.3V \pm 10%

5.3 Current Consumption

Operating : 8mA MAX(at 3.3V, 25°C)

Stand-by : 10 μ A MAX(at 3.3V, 25°C)

5.4 Output Level

C-MOS

5.5 Load Capacitance

30 pF

6.Electrical characteristics

6.1 Frequency Stability (Inclusive of 25°C tolerance, temp. characteristics, and supply voltage change)

 $\pm 100 \times 10^{-6}$ MAX

6.2 Output Voltage

 V_{OL} ; 0.1 V_{DD} MAX V_{OH} ; 0.9 V_{DD} MIN6.3 Rise Time(T_r) / Fall Time(T_f)5 ns MAX(0.1 V_{DD} ~0.9 V_{DD})

6.4 Symmetry

45 ~ 55 % (at 1/2 V_{DD})

6.5 Output Wave Form

Rectangular

6.6 Start-up Time

4 ms MAX

6.7 Stand-by function

#1 PAD input	# 3 PAD output
H level (0.7 V_{DD} ~ V_{DD}) or open	Operating
L level (0.3 V_{DD} MAX)	High impedance

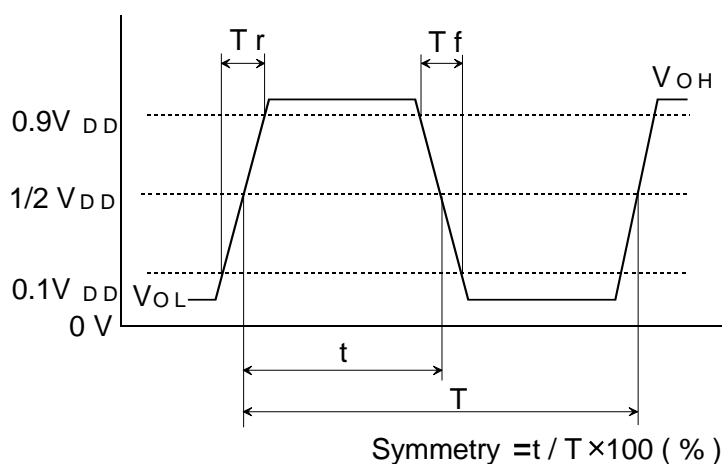

7.Measuring circuits

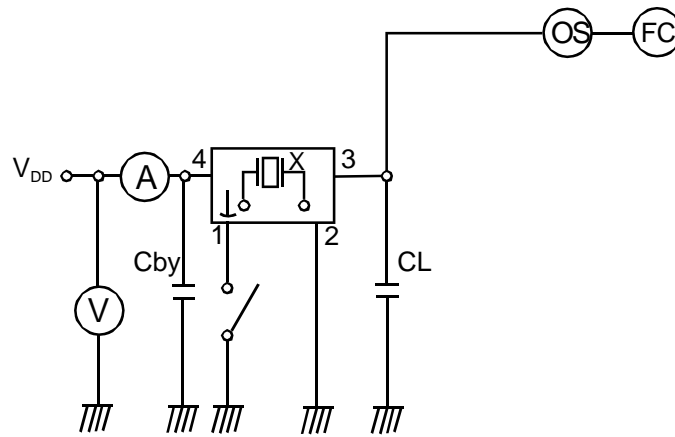

CL ; 15pF MAX including input capacity of osilloscope

Cby ; Bypass condenser (0.01 μ F)

8. Test data will not be submitted.

9. Application drawing

9.1 Dimension drawing

EKD14B-00026

9.2 Marking drawing

EKH11B-00051

9.3 Reliability assurance Item

EKS30B-00092

9.4 Taping & Reel drawing

EKK17B-00002

EEK17B-00015

10. Instruction Notice

10.1 Noise

When the 2700 series are used, the 0.01 μ F capacitor should be connected between V_{DD} and GND line. (Closer to the product terminal is desirable.)

10.2 Resistance to dropping

The 2700 series is designed to be impactproof so that no damage occurs when dropped a height(75 cm) three times. However, if dropped from a desk etc., it is advisable to check their performance or contact us to check it.

10.3 Electrostatic protection

The 2700 series employ C-MOS ICs for the active element. Please use them in static-free environments.

10.4 High temperature

Normal operation cannot be guaranteed for the 2700 series at +125 $^{\circ}$ C(for 24 hours). Be sure that the units are kept within the specified temperature range.

10.5 Cleaning

Basically, the 2700 series are applicable for ultrasonic wave cleaning. However, in some case, during ultrasonic wave cleanings, internal design may get damage. Please check condition carefully beforehand.

10.6 Other

The 2700 series are C-MOS applied products. And careful handling(same as with C-MOS IC) are needed to avoid electrostatic problems.

Incorrect PAD connection is cause of trouble. Please make sure to connect correctly as below.

#2 terminal \rightarrow GND

#4 terminal \rightarrow V_{DD}

11. Notice

- 11.1 Order items are manufactured according to specification. As to conditions, which are not indicated in this specification and unpredictable such as applied condition and oscillation margin, please check them beforehand.
- 11.2 Unless we receive request for modification within 3 weeks from the issue date of this NDK specification sheet, we will supply products according to this specification. Also, if you'd like to modify specification of order, which has been placed with delivery request within 3 weeks from the issue data of this specification sheet, we would like to discuss with you separately.
- 11.3 In no event shall the company be liable for any product failure resulting from an inappropriate handling or operation of the product beyond the scope of its guarantee.
- 11.4 Where any change to the process condition is made due to the change(s) in the production line, inform personnel of the specifications.
- 11.5 Should this specification data give rise to any disputes relating to any intellectual property rights or any other rights of a third person, the company shall not indemnify anyone for any damage. Their disclosure must not be construed as the grant of a license to use any of the intellectual property rights owned by the company.
- 11.6 If you intend to use products listed on this specification for applications that may result in loss of life or assets (controls relating to safety, medical equipment, aeronautical equipment, space equipment, etc.), please do not fail to advise us of your intention beforehand.
- 11.7 In the company's production process whatever amount of ozone depleting substances (ODS) as specified in the Montreal protocol is not used.
- 11.8 Information contained in this specification must not be quoted, reproduced or used for other purposes including processing either in part or in full without obtaining prior approval from the company.

12. Prohibited items

Be sure to use the product under the following conditions. Otherwise, the characteristics deterioration or destruction of the product may result.

(1)Reflow soldering heat resistance

Peak temperature: 265°C, 10 sec

Heating: 230°C or higher, 40 sec

Preheating: 150°C to 180°C, 120 sec

Reflow passage times: 3 times

(2)Manual soldering heat resistance

Pressing a soldering iron of 410°C on the terminal electrode for 4 seconds (twice).

*Example For Soldering Conditions (The below graph corresponds to Pb free solder)

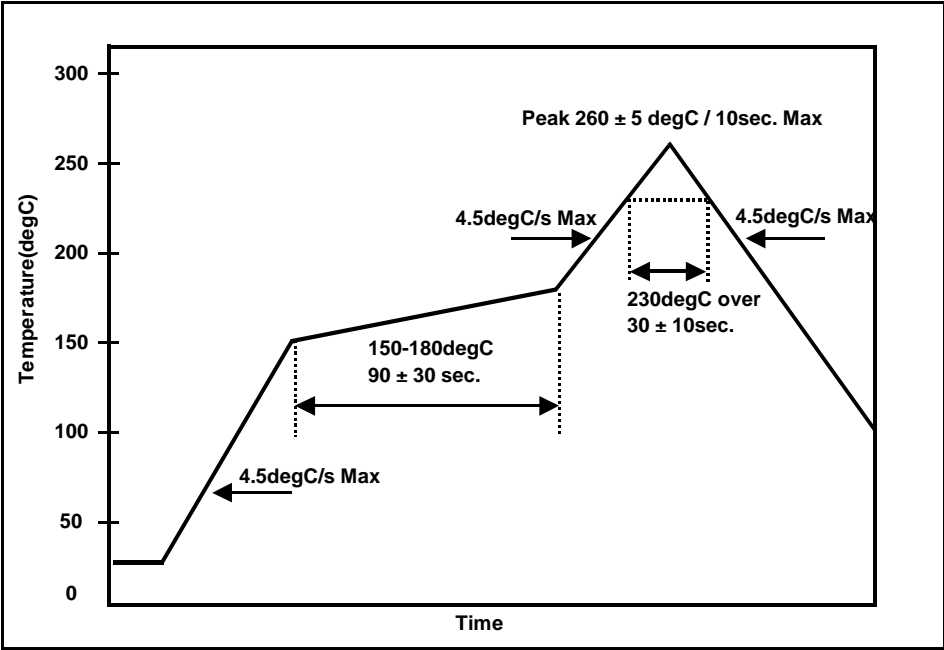

* Recommended footprint [mm]

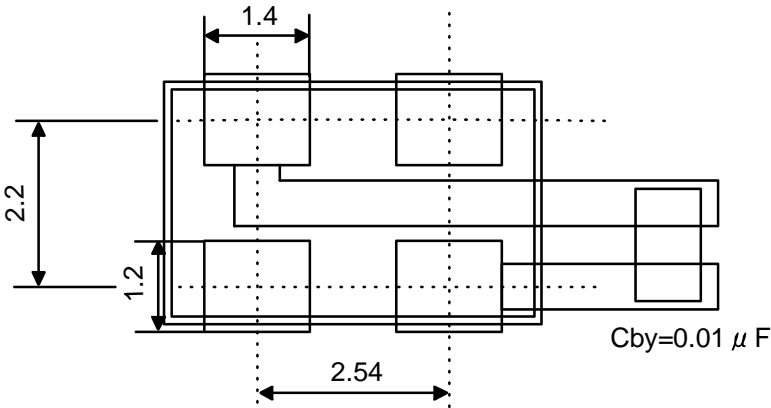

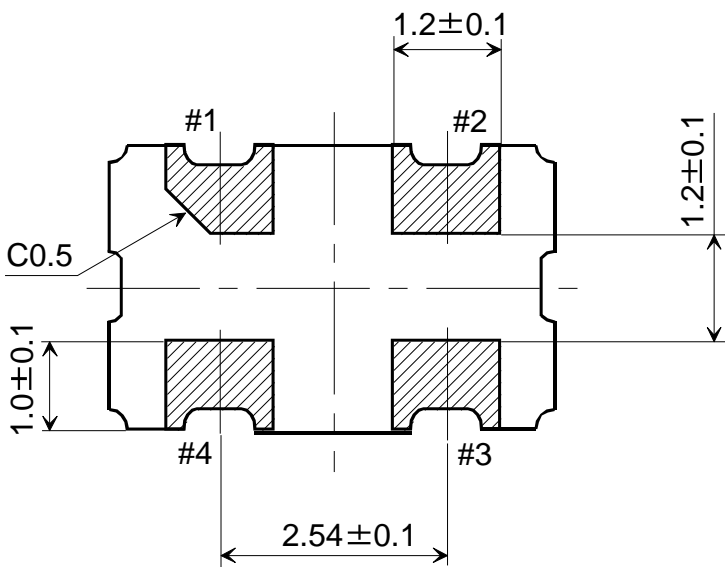
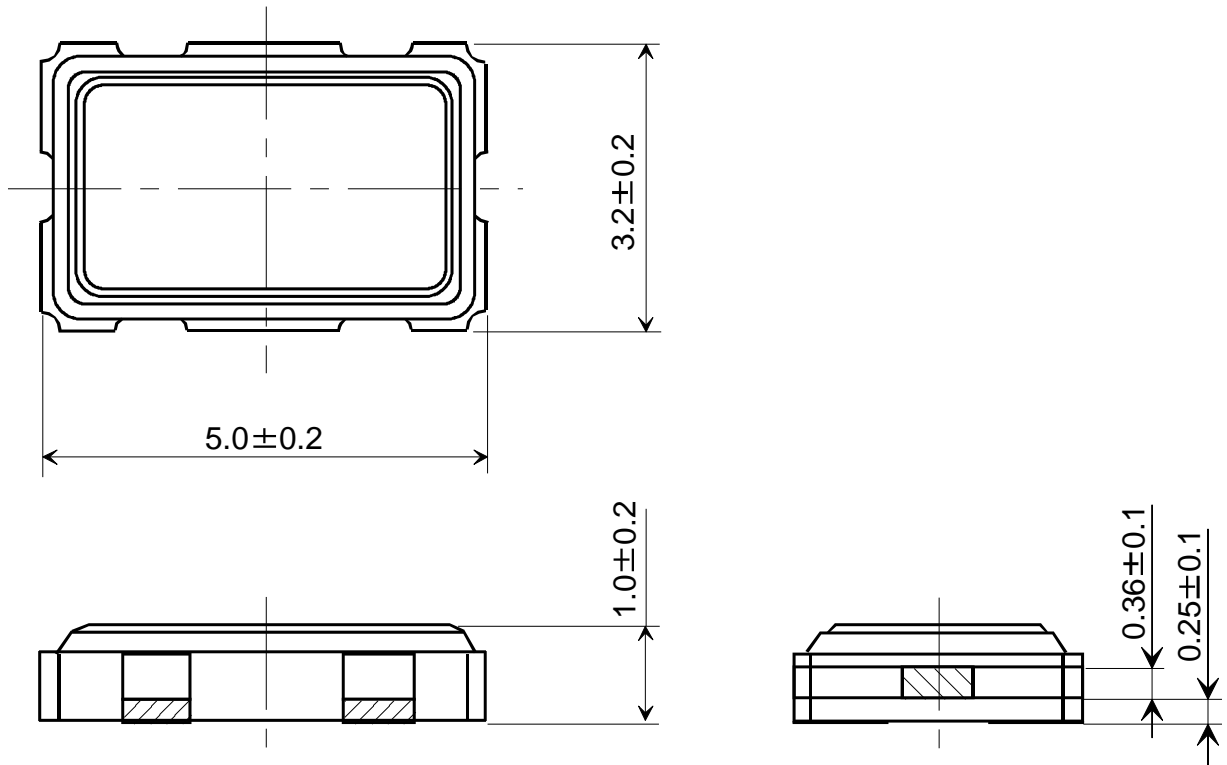

2700

PAD	CONNECTIONS
#1	STAND-BY
#2	GND
#3	OUTPUT
#4	V _{DD}

The coplanarity of PAD #1,#2,#3,#4 : 0.1mm MAX.

Date of Revise	Charge	Approved	Reason		
C 24.Jul.2009	S.Murase	C.Ishimaru	VDD→V _{DD} change		
Drawn	Date	Name	Third Angle Projection	Tolerance	Scale
9.Sep.2003	A.Yokota	Dimension:mm	-----	-----	
Designed	9.Sep.2003	M.Yamaguchi	Title	Drawing No.	Rev.
Checked	-----	-----	2700 Dimension of External	EKD14B-00026	C
Approved	9.Sep.2003	H.Omata			

NIHON DEMPA KOGYO CO., LTD.

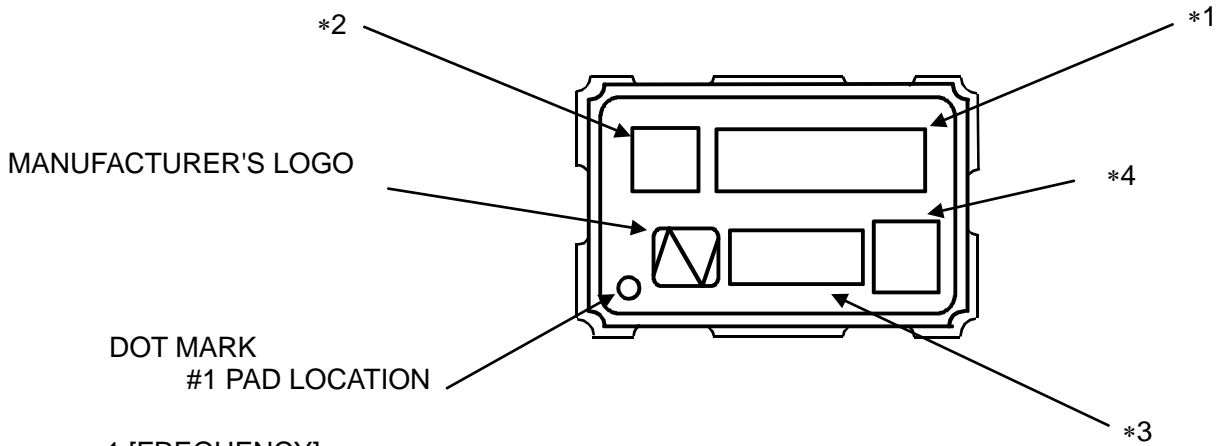

*1 [FREQUENCY]
 Digits are five and 6TH digit will be omitted.
 MHz unit sign is not marked.
 ex,) 28.63636MHz → 28.636 [Unit sign not marked]

*2 [MODEL MARK]
 A last digit of model is marked.

[MODEL MARK]	
2700N	→ Space
2700T	→ T
2700Z	→ Z
2700Q	→ Q

*3 [WEEK CODE (Digit are three)]
 ex1,) In case of 7TH week of 1999

9 0 7

Week No. (Digit are two)
 Lower one digit of year

ex2,) In case of 7TH week of 2000
 0 0 7

*4 [Trace code]
 Trace code consists of four digits number or letter.
 This code indicates production date and production line number.

[THE KEY MODEL] 2700

Date of Revise	Charge	Approved	Reason		
	Date	Name	Third Angle Projection	Tolerance	Scale
Drawn	27.Jan.2006	Y.Oishi	mm	-----	-----
Designed	27.Jan.2006	Y.Oishi	Title 2700 Marking	Drawing No. EKH11B-00051	Rev.
Checked	27.Jan.2006	C.Ishimaru			-
Approved	27.Jan.2006	H.Omata			-

NIHON DEMPA KOGYO CO., LTD.

Environmental Test Conditions	Specification
1. Pre- and Post-Stress Electrical Test Refer to AEC-Q200-REV.C TABLE.11 NO.1	*1
2. High Temperature Exposure (Storage) Refer to AEC-Q200-REV.C TABLE.11 NO.3	*1
3. Temperature Cycling Refer to AEC-Q200-REV.C TABLE.11 NO.4	*1
4. Moisture Resistance Refer to AEC-Q200-REV.C TABLE.11 NO.6	*1
5. Biased Humidity Refer to AEC-Q200-REV.C TABLE.11 NO.7	*1
6. Operational Life Refer to AEC-Q200-REV.C TABLE.11 NO.8	*1
7. External Visual Refer to AEC-Q200-REV.C TABLE.11 NO.9	*2
8. Physical Dimension Refer to AEC-Q200-REV.C TABLE.11 NO.10	*3
9. Resistance to Solvents Refer to AEC-Q200-REV.C TABLE.11 NO.12	*1, *2
10. Mechanical Shock Refer to AEC-Q200-REV.C TABLE.11 NO.13	*1
11. Vibration Refer to AEC-Q200-REV.C TABLE.11 NO.14	*1
12. Resistance to Soldering Heat Refer to AEC-Q200-REV.C TABLE.11 NO.15	*1
13. Thermal Shock Refer to AEC-Q200-REV.C TABLE.11 NO.16	*1
14. Solderability Refer to AEC-Q200-REV.C TABLE.11 NO.18	*4
15. Electrical Characterization Refer to AEC-Q200-REV.C TABLE.11 NO.19	*1
16. Board Flex Refer to AEC-Q200-REV.C TABLE.11 NO.21	*5
17. Terminal Strength Refer to AEC-Q200-REV.C TABLE.11 NO.22	*5
<p>*1 After the test mentioned above, the electrical specifications are satisfied. Also frequency deviation before and after test should be $\Delta F/F \leq \pm 10 \times 10^{-6}$</p> <p>*2 Inspect device construction, marking, and workmanship.</p> <p>*3 External is satisfied.</p> <p>*4 95% min. covered by new solder.</p> <p>*5 Visual inspection to confirm no cracking of materials and no break of sealing.</p> <p>The electrical specifications are I_{CC}, T_r/T_f, V_{OL}/V_{OH}, duty cycle, stand-by current consumption.</p>	

Reel

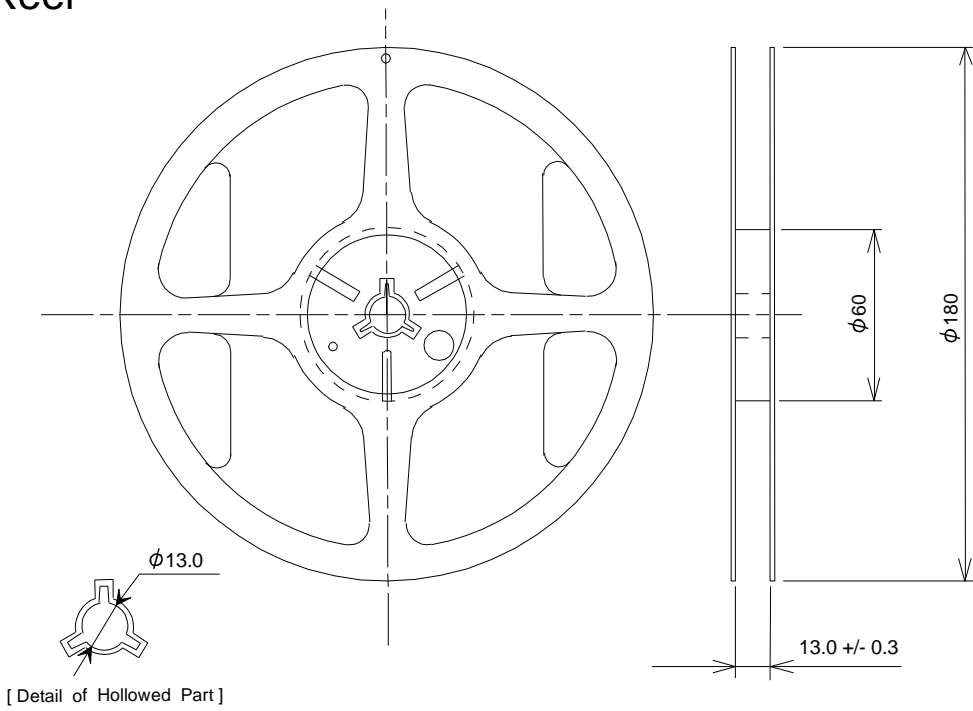

Tape

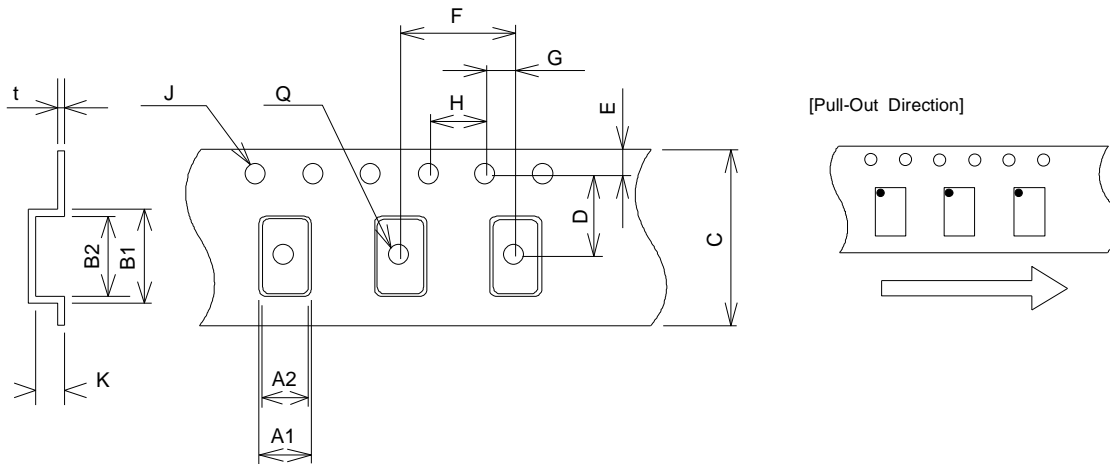

	A1	A2	B1	B2	C	D	E
Size	3.70 +/- 0.10	3.50 +/- 0.10	5.60 +/- 0.10	5.40 +/- 0.10	12.0 +/- 0.20	5.50 +/- 0.10	1.75 +/- 0.10

	F	G	H	J	K	Q	t
Size	8.00 +/- 0.10	2.00 +/- 0.10	4.00 +/- 0.10	1.50 ^{+0.1} ₋₀	1.40 +/- 0.10	1.50 ^{+0.1} ₋₀	0.30 +/- 0.05

10 pitch : 40.0 +/- 0.15mm

D and G are taken as the value between a pocket center

	Date of Revise	Charge	Approved	Reason	
A	15.Feb.2001	S.Murakami	H.Omata	Remake with the new form by a form change.	
Drawn	Date	Name	Third Angle Projection	Tolerance	Scale
25.May.1999	N.Saito	Dimension:mm	-----	-----	
Designed	Date	Name	Title	Drawing No.	Rev.
25.May.1999	N.Saito				
25.May.1999	C.Ishimaru				
Checked	Date	Name	2700 Packing	EKK17B-00002	A
25.May.1999	C.Ishimaru				
Approved	Date	Name			
25.May.1999	H.Omata				

NIHON DEMPA KOGYO CO., LTD.

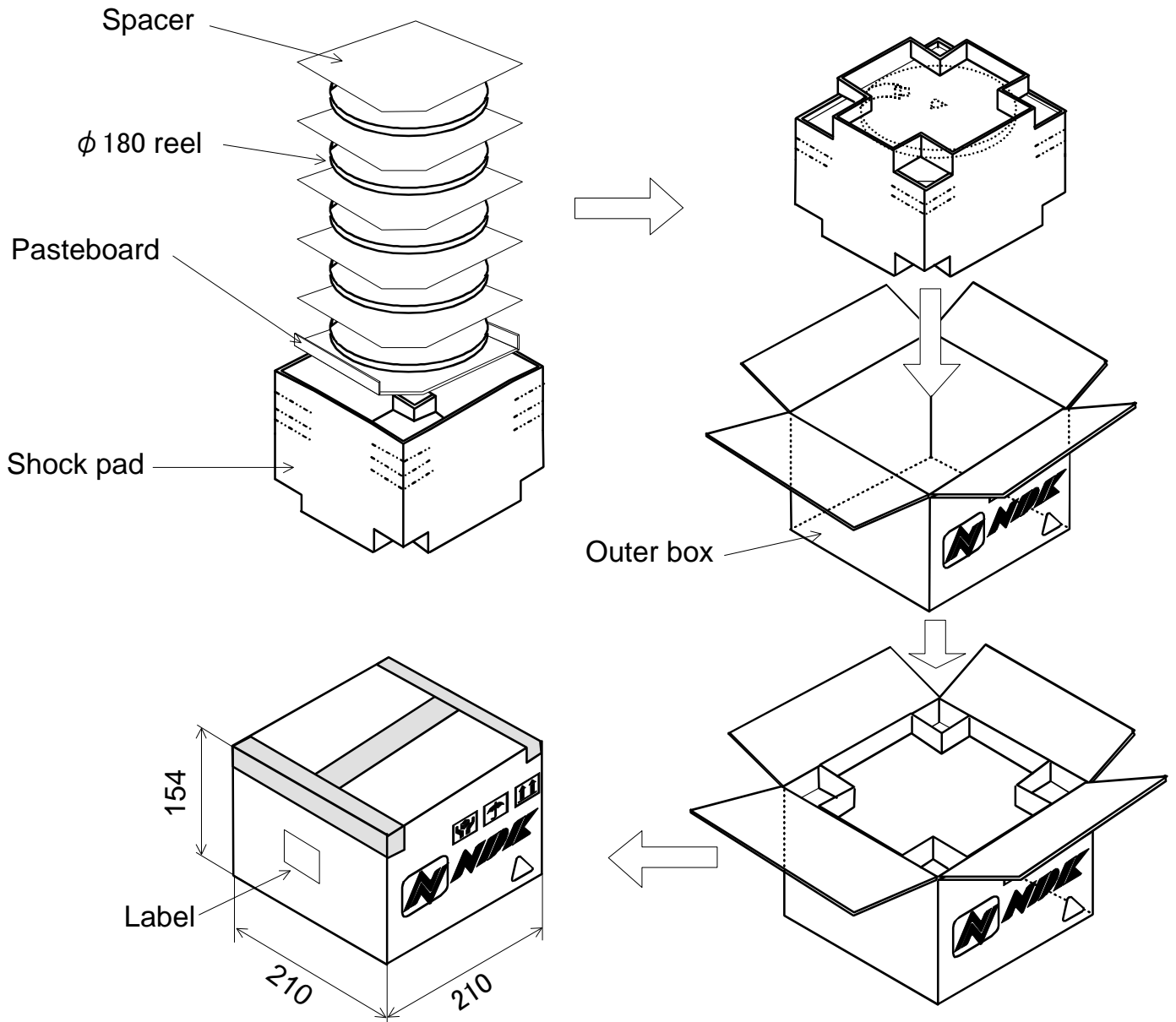

	Date of Revise	Charge	Approved	Reason	
B	19 May 2011	H. Ohkubo	K. Oguri	Correction of a clerical error.	
	Date	Name	Third Angle Projection	Tolerance	Scale
Drawn	26 Feb. 2010	H. Ohkubo	Dimension:mm	-----	-----
Designed	26 Feb. 2010	K. Oguri	Title 180 dia. Reel package	Drawing No. EEK17B-00015	Rev.
Checked	26 Feb. 2010	K. Oguri			B
Approved	26 Feb. 2010	J. Nakamura			

NIHON DEMPA KOGYO CO., LTD.