

REVISION RECORD				
REV	ECN	DESCRIPTION	DRFT	DATE

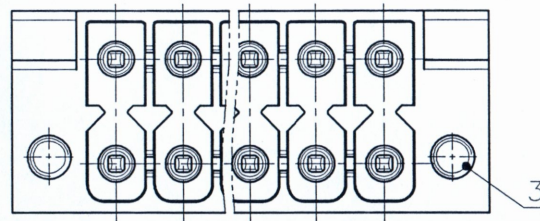

NOTES1:

UL Standard

- Rated voltage/current : 150V / 8A
- Withstanding voltage : AC1300V/1Min.

IEC Standard

1. Pollution degree	2	2	3
Overtoltage category	II	III	III
Rate impulse voltage(KV)	2.5KV	2.5KV	2.5KV
Rate voltage(V)	250V	160V	160V
Rate current(A)	8A		

NOTES2:

- Dimension shall be interpreted per ASME Y14.5-2009
- Pitch : 3.50mm, Poles : N=04~48P
- Operating temperature: -40°C~+130°C
- Undimensioned tolerances:

Pitch range in mm	Nominal dimension range in mm						0.1/10	
	Over 6 TO 10	Over 10 TO 24	Over 30 TO 30	Over 60 TO 60	Over 100 TO 150	Over 150		
±0.15	±0.20	±0.30	±0.30	±0.50	±0.70	±1.00	±1.30	±2°

5.RoHS Compliance

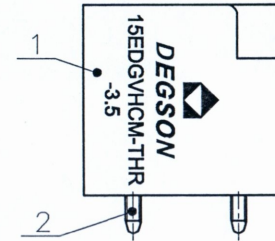
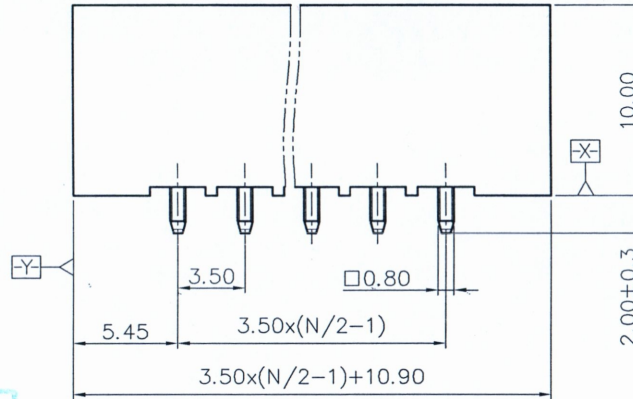
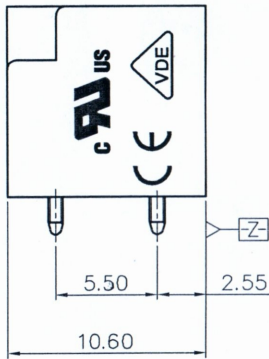

15EDGVHCM-THR - 3.5 - XXP - 1Y - 00A (H)
 (Series No.)(Pitch) (Poles)(Single Pitch) (Color):3.(Black) 9.(White)
 (RoHS)
 00A-(Standard)

3	Nut	Steel	M2/Zn Plated
2	Pin	Copper	Sn Plated
1	Housing	LCP	UL94V-0
ITEM	NAME OF PART	MATERIAL	NOTES

仅供参考图
 签字: 朱伟明
 日期: 2019.5.23

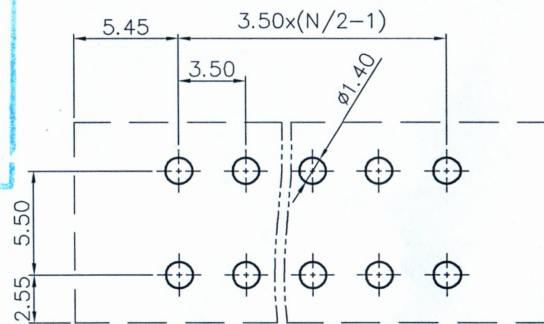

PCB LAYOUT

DETACHED LISTS	PART NO.:	宁波高松电子有限公司 NINGBO DEGSON ELECTRICAL CO., LTD		
	APPD: <i>Zhou Maozhen</i>	NAME: 15EDGVHCM-THR-3.5-XXP-1Y-00A(H)		
	CHKD: <i>2019.05.23</i>	TITLE: CUSTOMER DRAWING	REV: D0-1	SHEET: 1/1
	DRFT: XiaoShP 2019.05.23	DRAWING NO.: 15EDGVHCM-THR-3.5-C01	DO NOT SCALE DRAWING	SCALE: 1:1

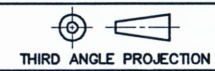

THIRD ANGLE PROJECTION

H
G
F
E
D
C
B
A

H
G
F
E
D
C
B
A