

Transfer or duplication of this document as well as the utilization or communication of its content are prohibited unless approval is granted. Violations will be held for compensation. All rights reserved for patent, utility model or design registrations. 除专利等明确标注外，其他标注均属于本公司保留的知识产权。未经许可，不得复制或传播。本公司保留对涉及发明、实用新型和外观设计的所有权利。

未注公差/General tolerances (mm)													0.1/10	
0	>3	>6	>10	>18	>30	>50	>80	>120	>180	>250	>315	>400		>500
±0.12	±0.18	±0.22	±0.26	±0.31	±0.37	±0.57	±0.80	±0.93	±1.05	±1.15	±1.60	±2.20	±2.50	±2'

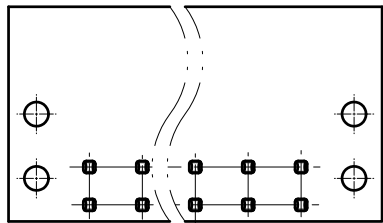
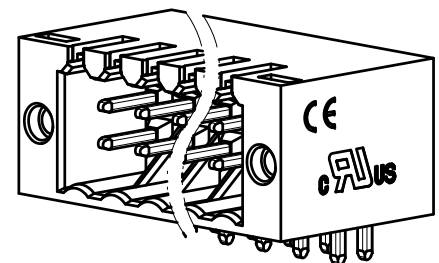
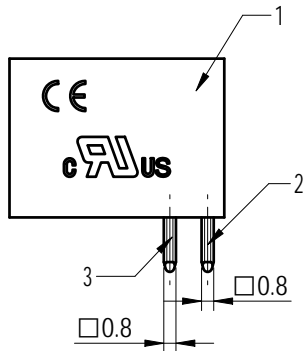
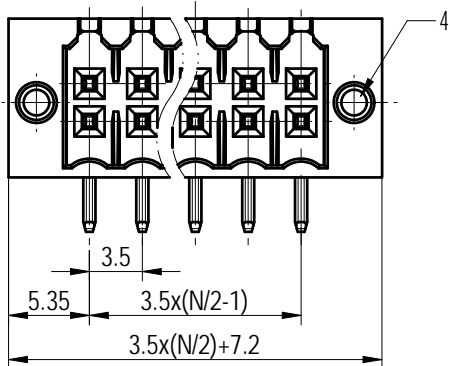
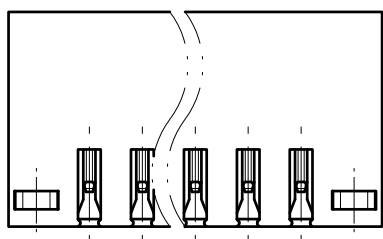
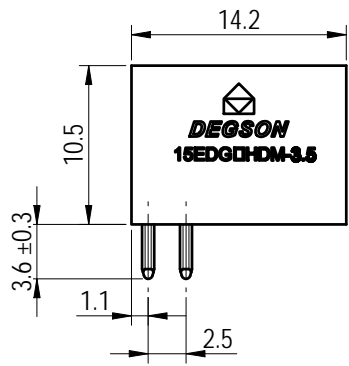
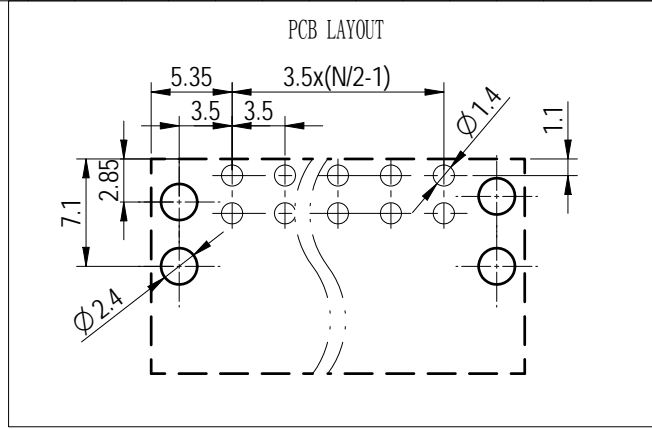

Note:
The A&Z(H) in the name means:A(H) and Z(H).

ITEM	NAME OF PART	MATERIAL	NOTES
4	Nut	Steel	M2/Zn Plated
3	Short pin	Copper	Sn Plated
2	Long pin	Copper	Sn Plated
1	Housing	PA66+GF	UL94V-0

UL 标准/UL Standard:	B	C	D
额定电压/电流/Rated Voltage(V)/Current(A)	150/10	/	/
IEC 标准/IEC Standard:			
过压类别/Overvoltage Category/污染等级/Pollution Degree	III/3	III/2	II/2
额定电压/电流/Rated Voltage(V)/Current(A)	160/10	200/10	400/10
额定脉冲电压(KV)/Rate Impulse Voltage(KV)	2.5	2.5	2.5
间距/Pitch(mm)/线数范围/Poles	3.5/N=04~48P		
使用温度范围/Operating temperature(°C)	-40~+105		
符合RoHS环保要求/Conform to RoHS	Yes		

		MATERIAL:	SURFACE/COLOR:			
		MAT NO./REV: - / 00	MAT STATUS: 批量			
APPD: 兰春华	2022.09.05	NAME				
CHKD: 龚耀志	2022.09.03	15EDGRHDM-3.5-XXP-1Y-00A&Z(H)				
DRFT: 周锡锦	2022.09.02	DRAWING NO.	TYPE	DRAWING STATUS	SCALE	SHEET
		200029718	CUSTOMER DRAWING	已发布	2:1	1/1

REV	ECN	DESCRIPTION	DRFT	DATE
00			周锡锦	2022.09.02